

银河封神纪

银河封神纪以科幻宇宙为题材，这个世界是以掌管四大元素，金、木、水、火、土五大元素组成，众多星球的环境各异，形形色色的异星人和诸神层出不穷。然而有一天，以创世神为首的邪恶势力对各个星球发起进攻，在绝对力量前，创世神彻底沦陷，落入邪恶手中。为了拯救宇宙，仅有的正义组织“昆仑”派出最后“王者”——李小白，杨光、黎明、凌云组成“封神小队”，展开一场热血的宇宙大冒险。他们一边利用超级机器人“机神”拯救无辜的人们，一边追查线索寻找唯一能逆转时空命运的“封神秘术”！这就是系四宇宙的最后希望——封神计划。

雷鸟机神

阵营：封神小队 驾驶员：雷羽

机神身高：17米 机神重量：15吨 能量属性：★电

武器：反雷长矛

必杀技：天罚电击！雷霆万钧

机神六维数据

格斗：A 射击：B 敏捷：A 防御：C 魔法：A 成长：1：B

综合雷属性，闪电、飞鸟作为概念设计的战斗机器人，具有飞行能力，擅长从空中发动的超速度机体，主推进器有超加速能力，带动机体在空中飞行时做出超距离的超加速移动。能够吸收大气中的雷电，使出各种各样元素系雷系招式，背后的羽翼也能射出，化为超高速攻击人的超加速雷刃。



雷羽

雷鸟机神



念动浮游剑

盾牌

风雷长矛



位于祁山之中的神秘巨洞深处藏着一批传说中的奇门宝剑。传说只有被选中的人，才能将之取出，从而驱散妖雾。作为被选中的山羽，在激动伙伴与辰皇宝刹之间百炼成钢。最终，成功取出奇门剑，黄雀王威显露在世人眼前。

A板件



B1板件

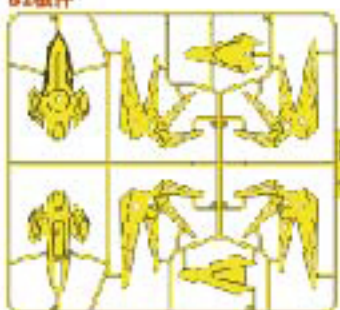

B2板件

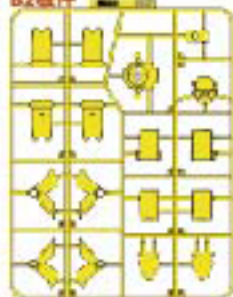

B3板件

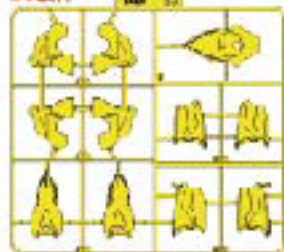

B4板件



B5板件

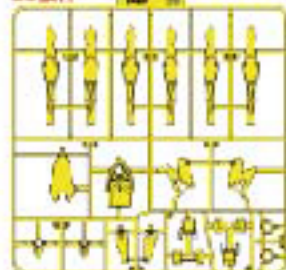

C板件

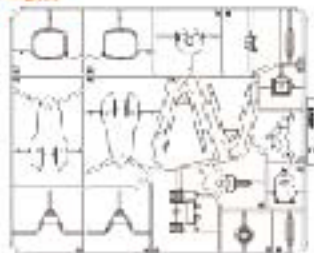

D1板件

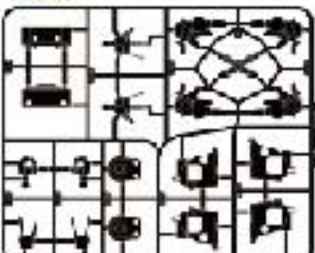

D2板件

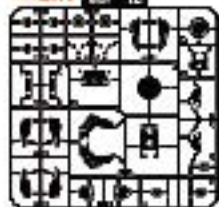

积木零件列表



组装此款模型的方法

01 找到零件的编号

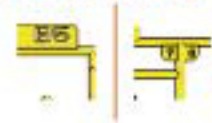

板件编号 E6 7 零件编号

02 小心的将零件按压下来



03 将零件组合在一起



完成



*本产品采用免剪钳手拆式水口, 按压取下零件时小心模型水口尖点

1 头部组件

所需板件

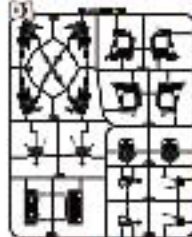
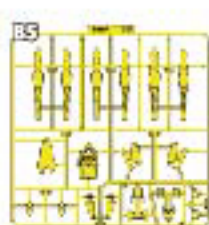
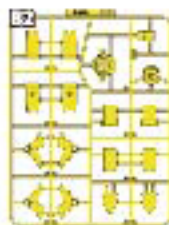

板件编码 A1 X
零件编码 XI

1-1



1-2

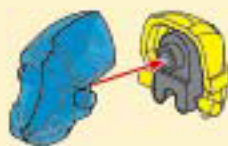
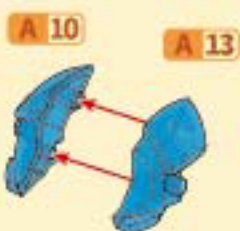

1-3

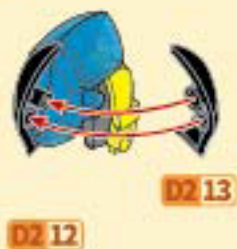

1-4



1-5

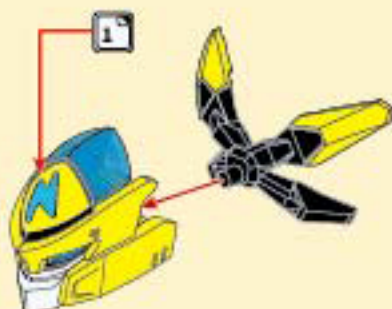
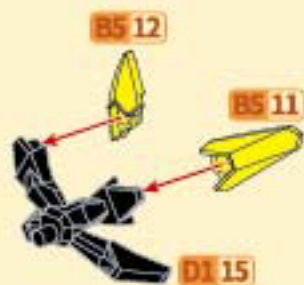

2 上身组件

所需板件

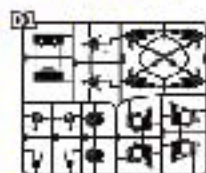
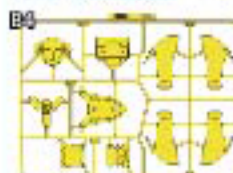
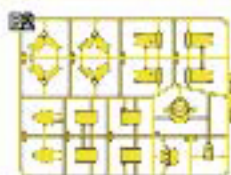

板件编码 零件编码
A3 X

2-1

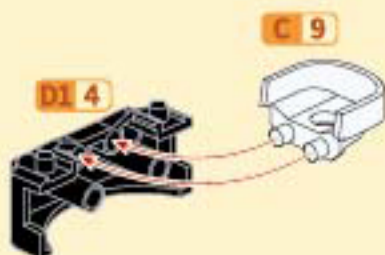

2-2

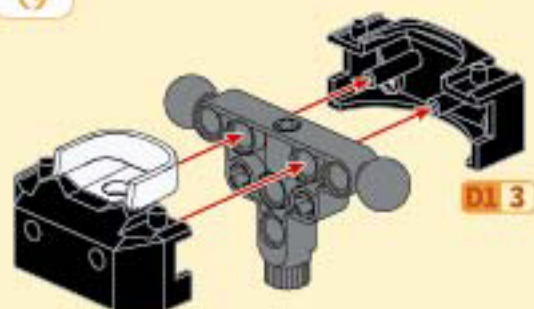

2-3

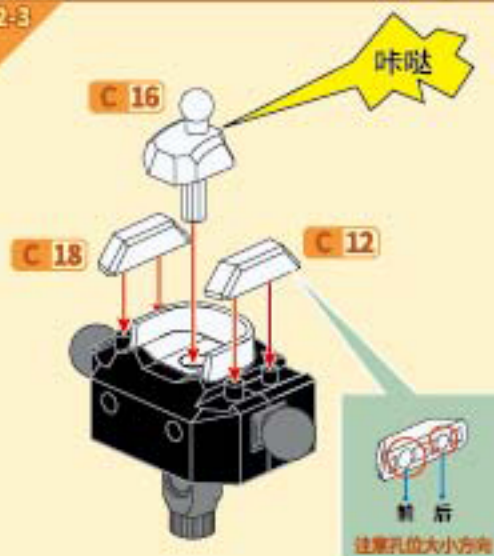

2-4

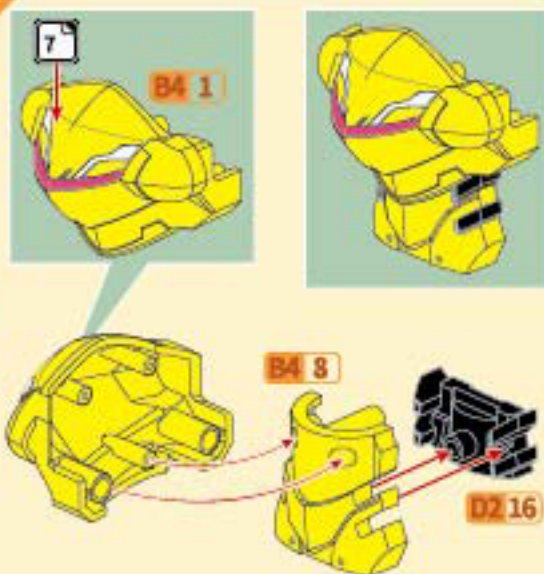

2-5

拼装顺序: 先上 → 后下 →

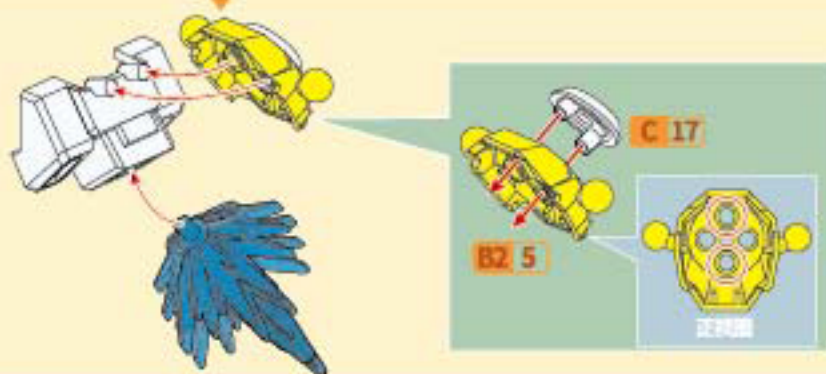
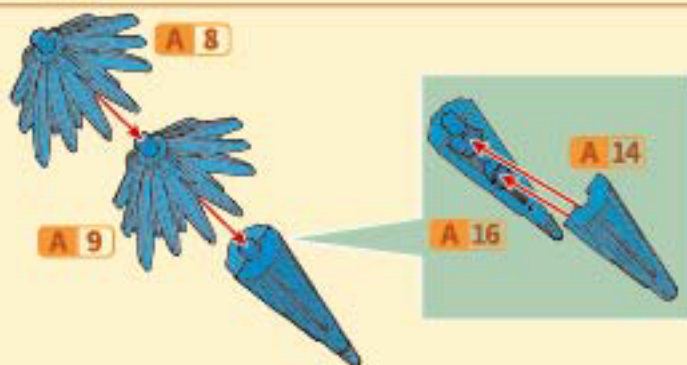
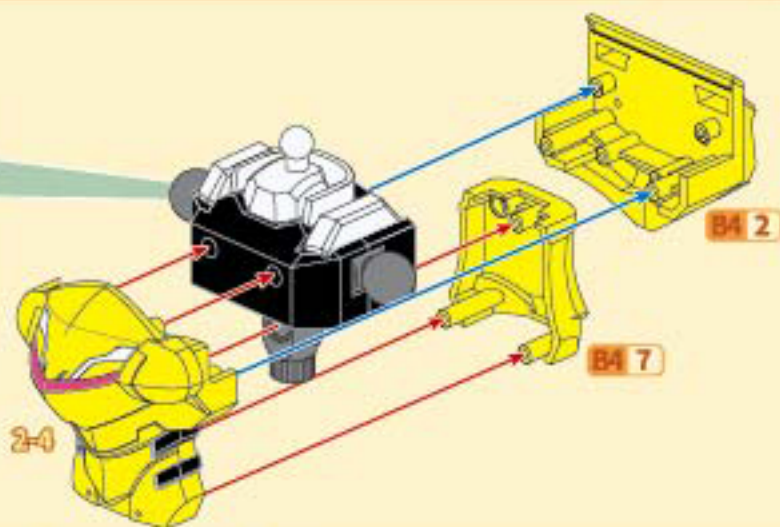

2-6

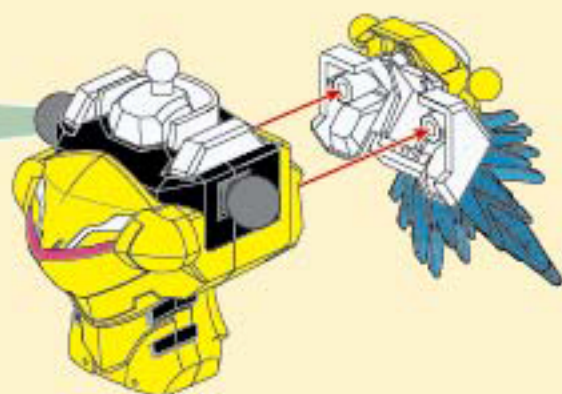
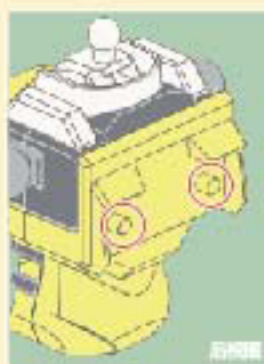

3 腰部组件

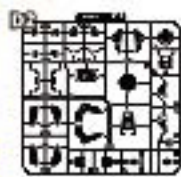
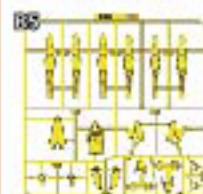
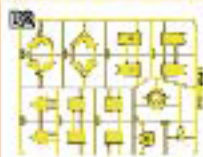

所需板件

板件编码: A1 X
零件编码: X1, X2

3-1

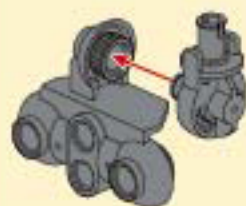

3-2

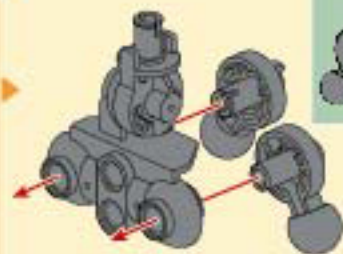

3-3

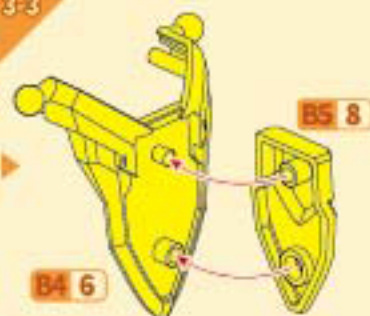

3-4

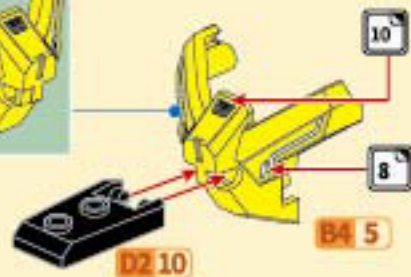
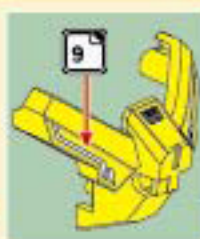
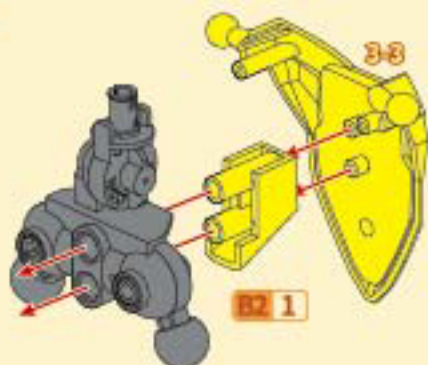

3-5



15

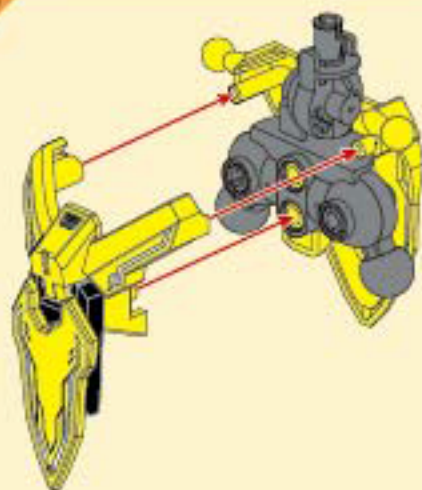
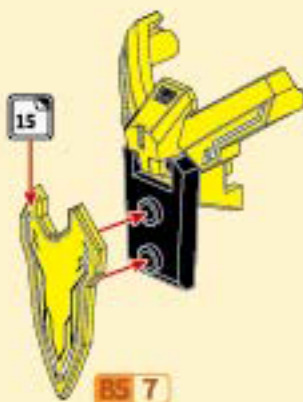

4 右手组件

所需板件

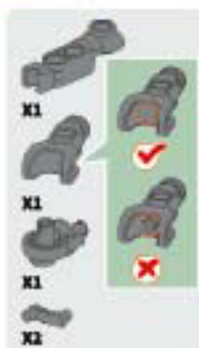
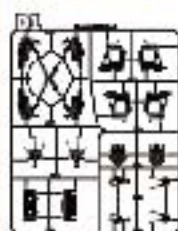
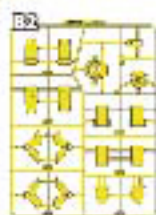
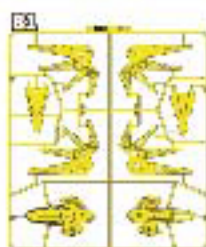
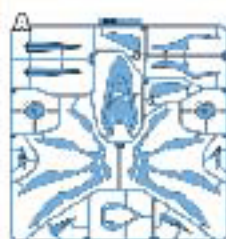

板件编码 零件编码
X1 X1 X1 X2

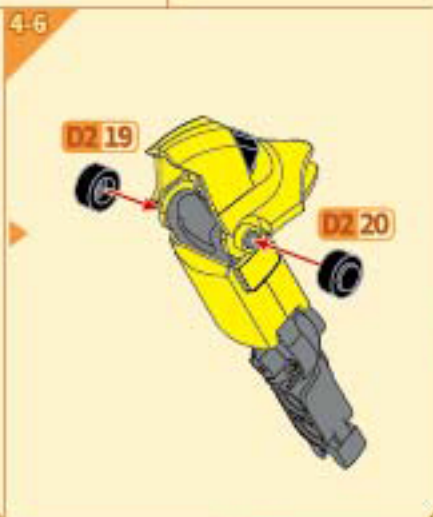
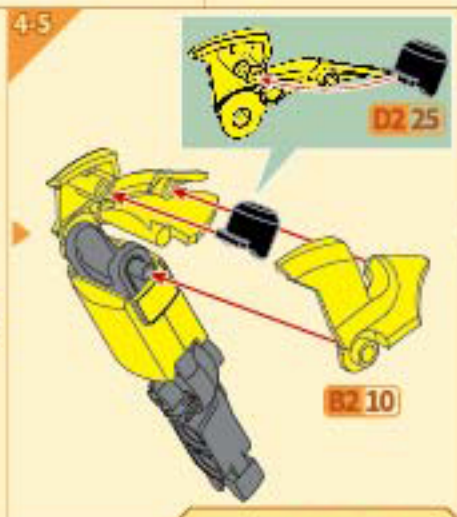
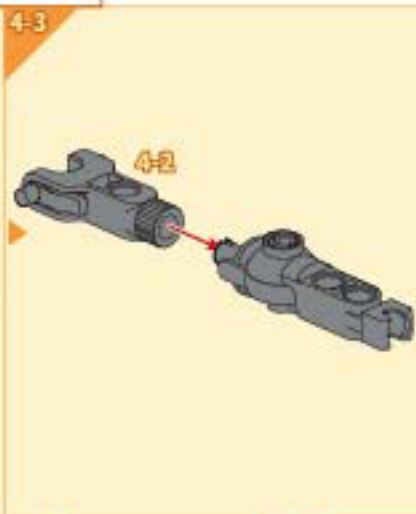
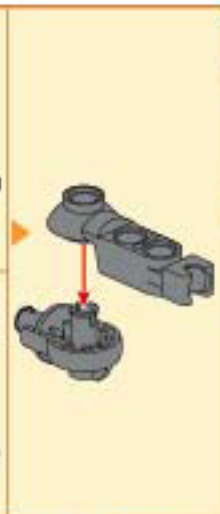

4-7



D1 6

4-8



D1 5

D1 7



4-9



4-10

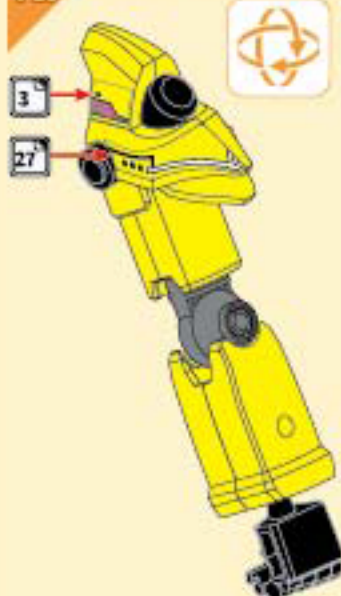

4-11

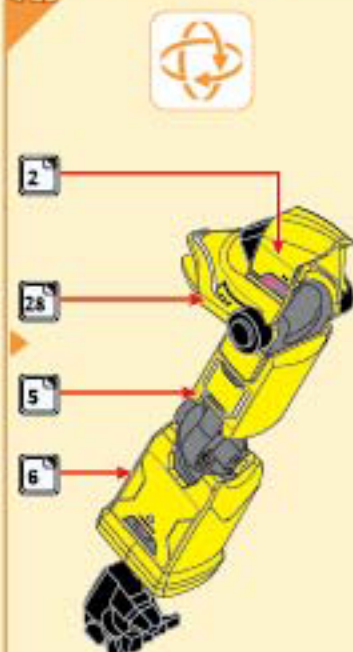

4-12



4-13

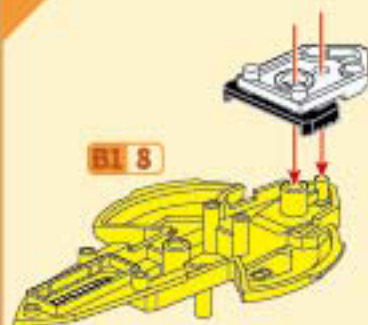

4-14

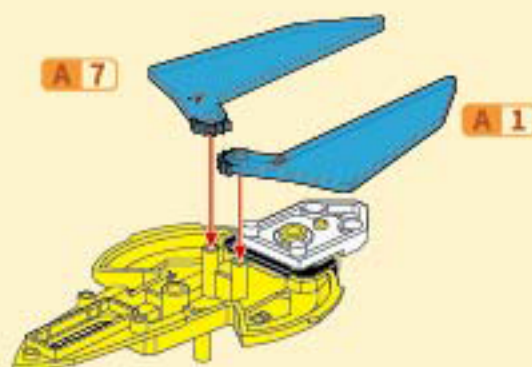
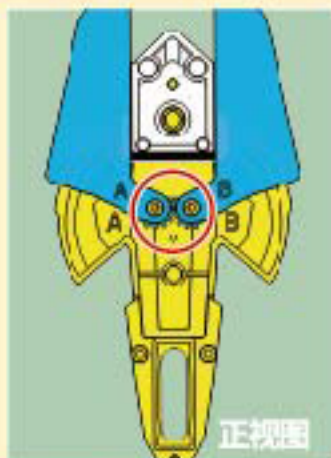

4-15

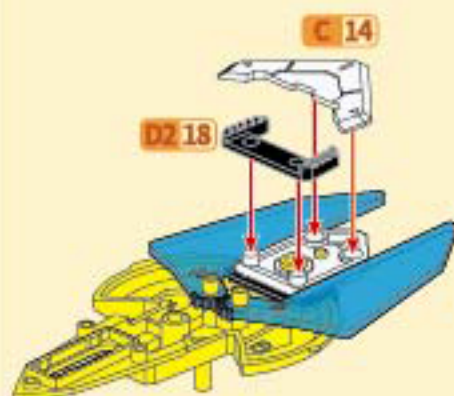

4-16

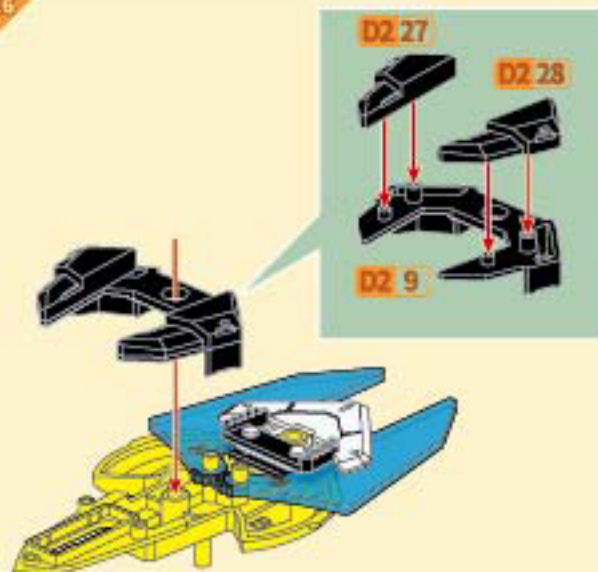

4-17

拼装顺序：先蓝 → 后红 →

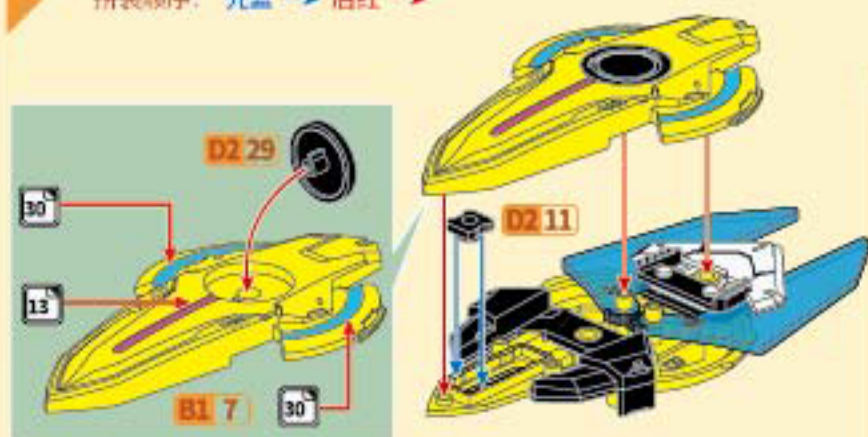

玩法：



4-18

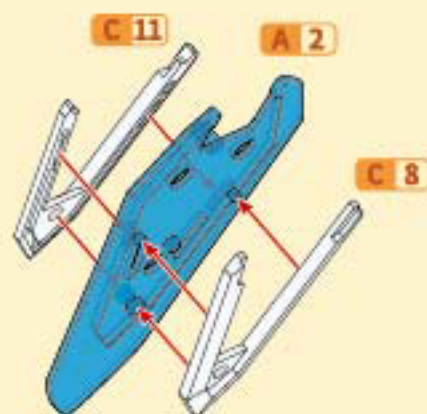

4-19

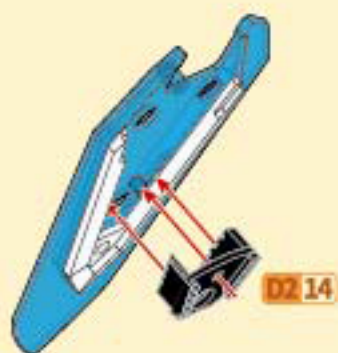

4-20

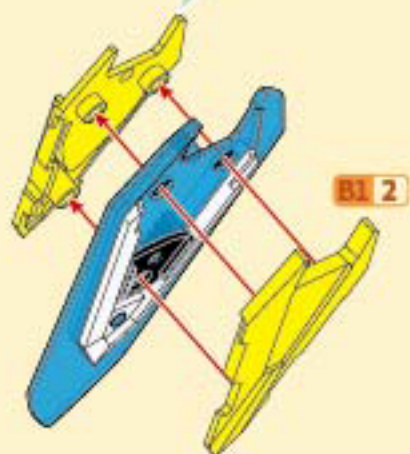
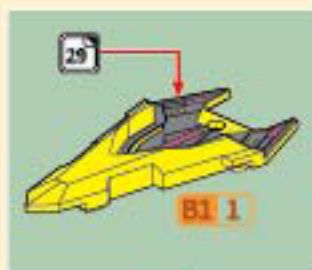

4-21

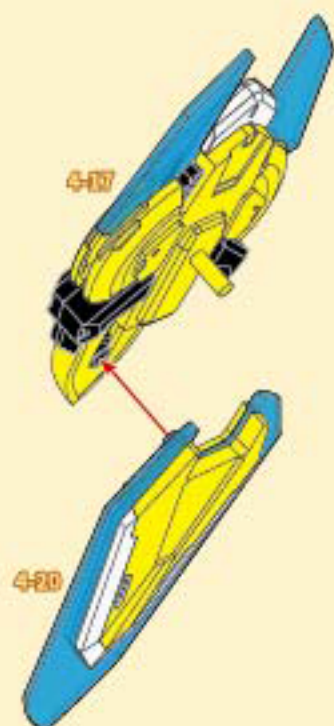

4-22

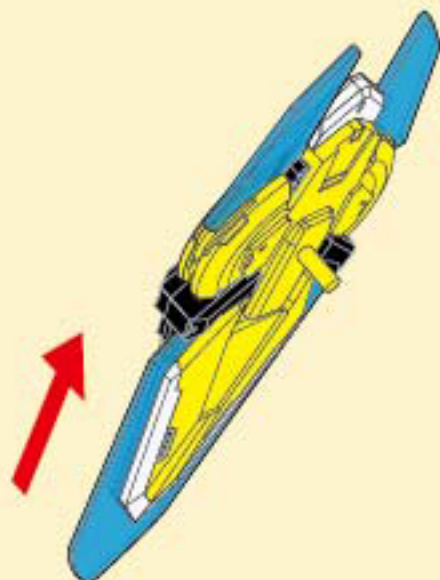

4-23

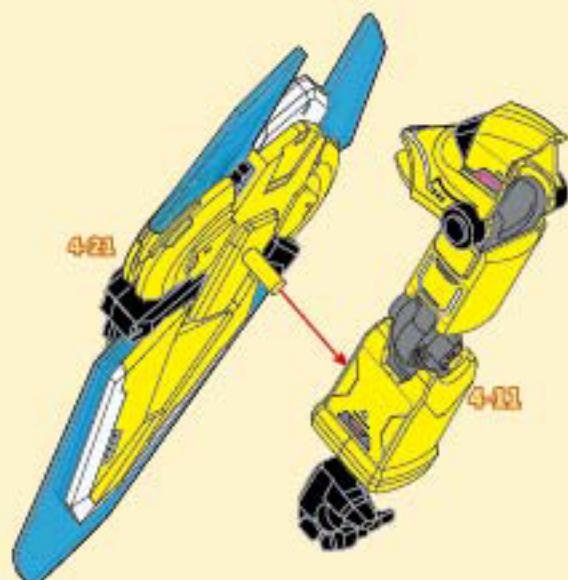

5 左手组件

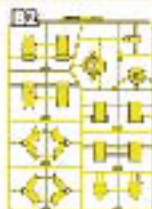
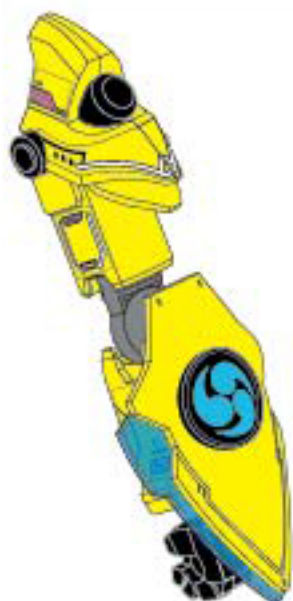

所需板件

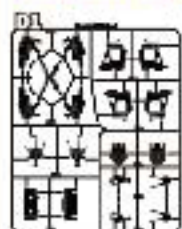
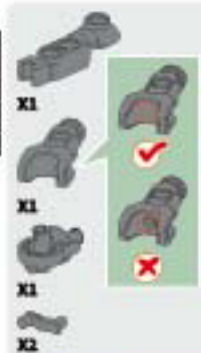
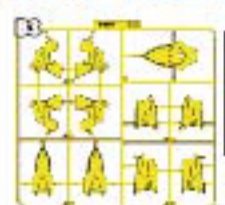

板件编码 零件编码
A1 X

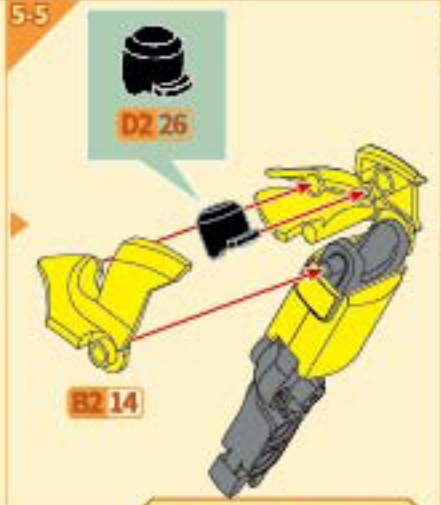
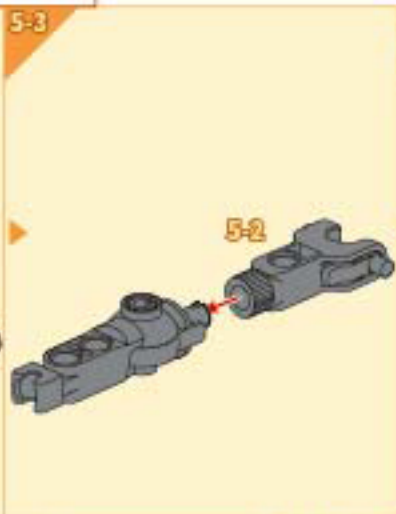
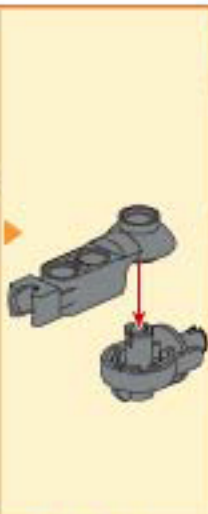

5-7



5-8



5-9

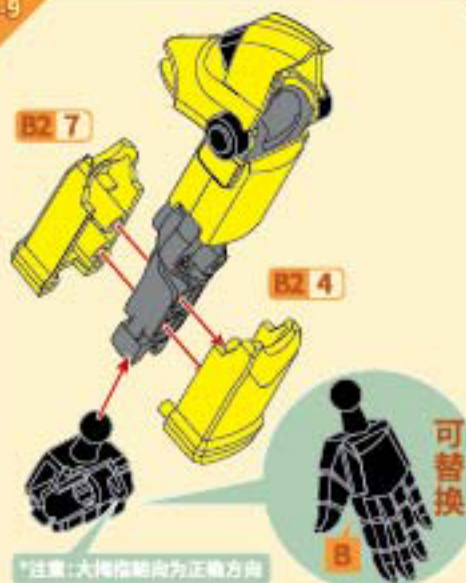

5-10

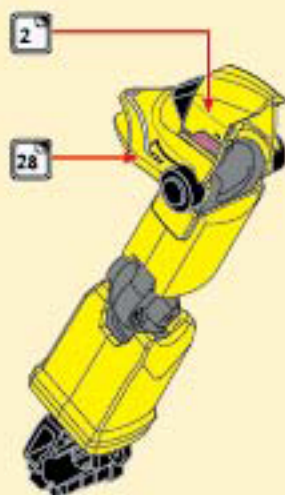

5-11

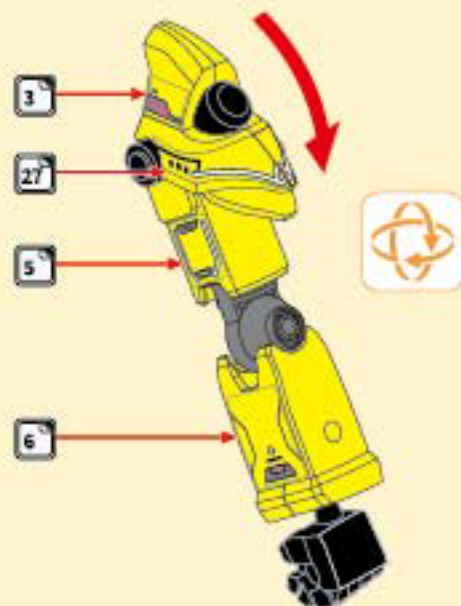

5-12

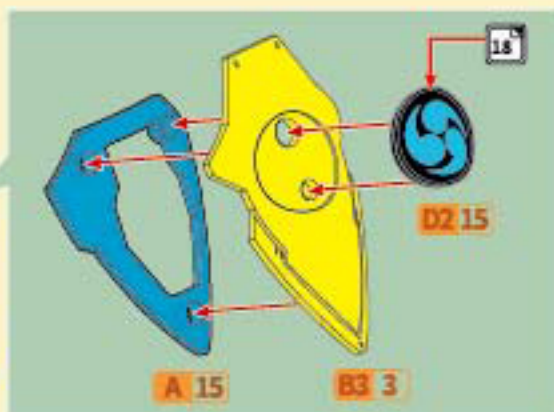
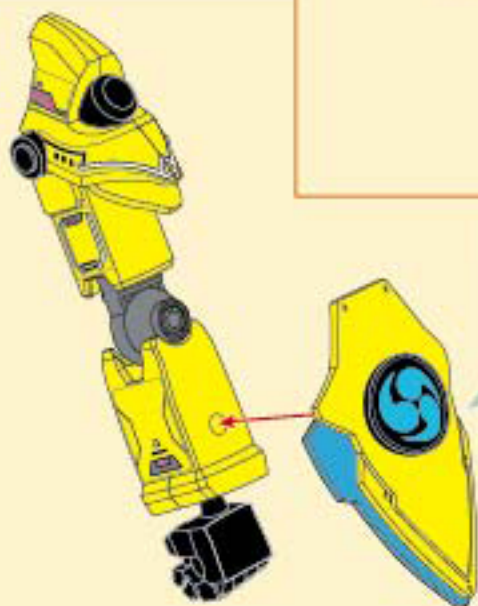

6 右脚组件



所需板件



板件编码 零件编码
A1 X



6-1

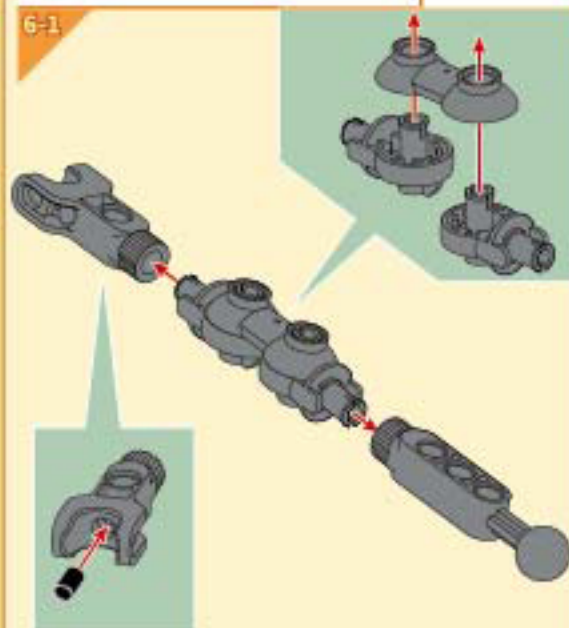

6-3

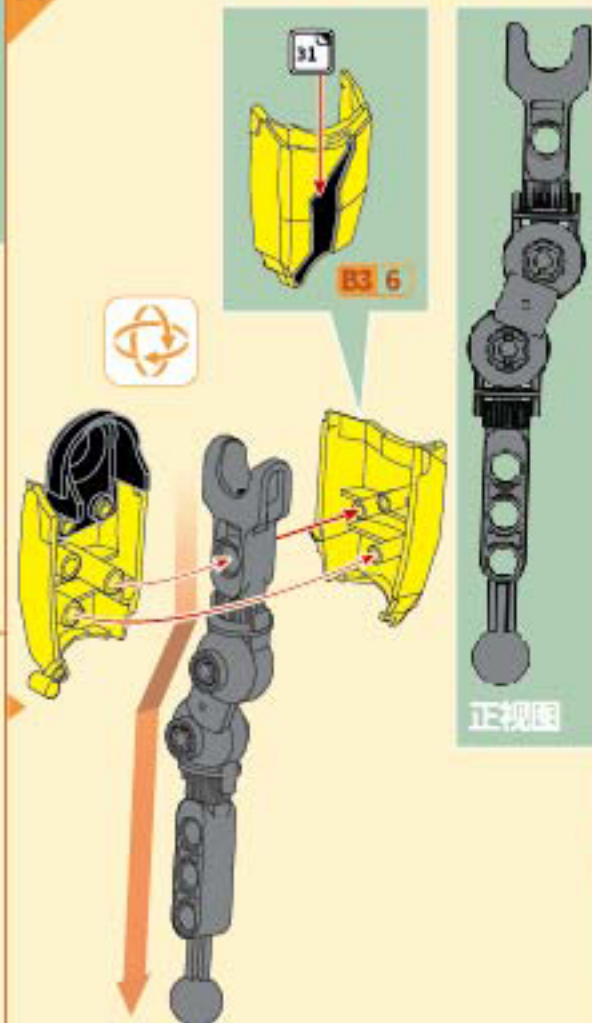

6-2



6-4

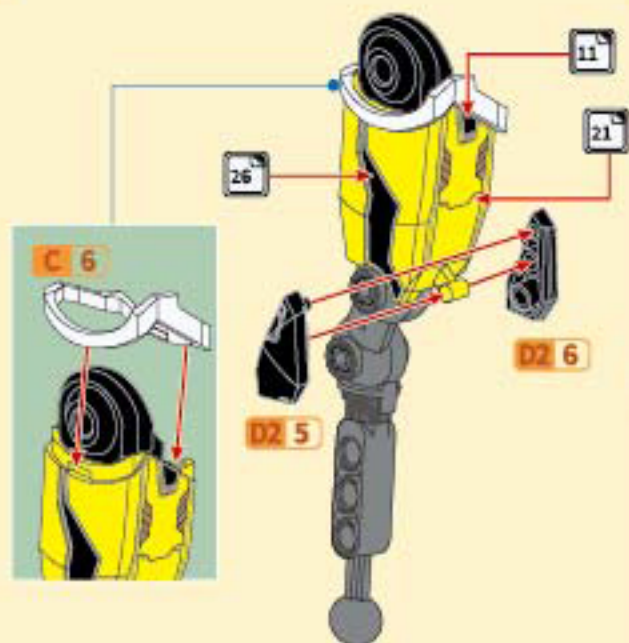

6-5

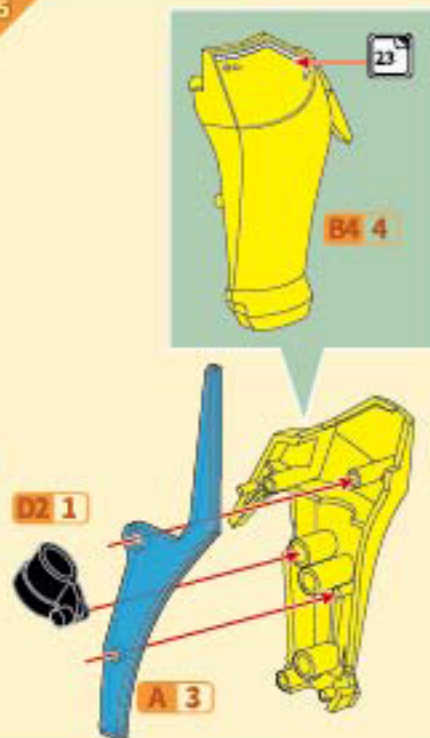

6-6

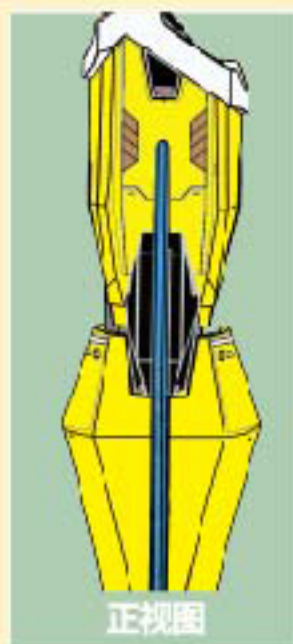
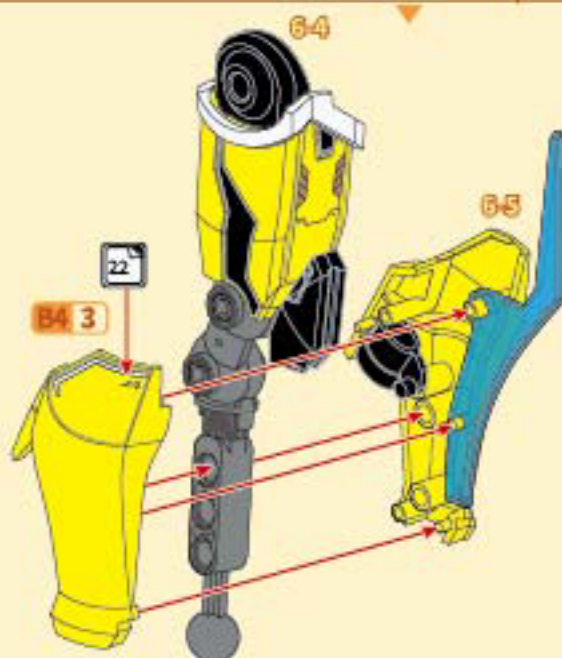

6-7

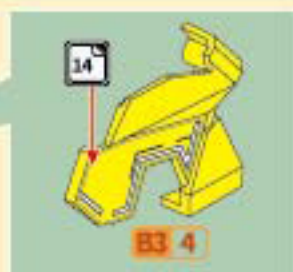
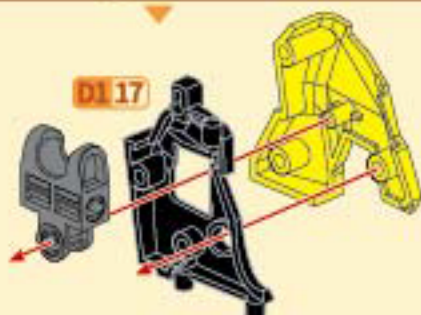

6-8

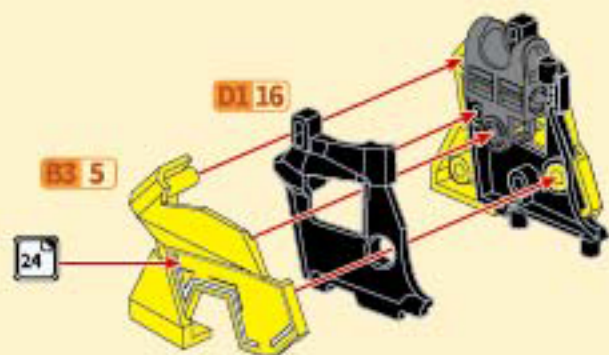

6-9

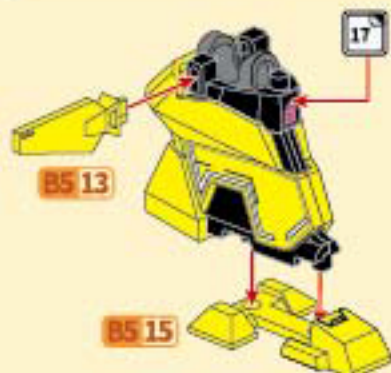

6-10



6-11

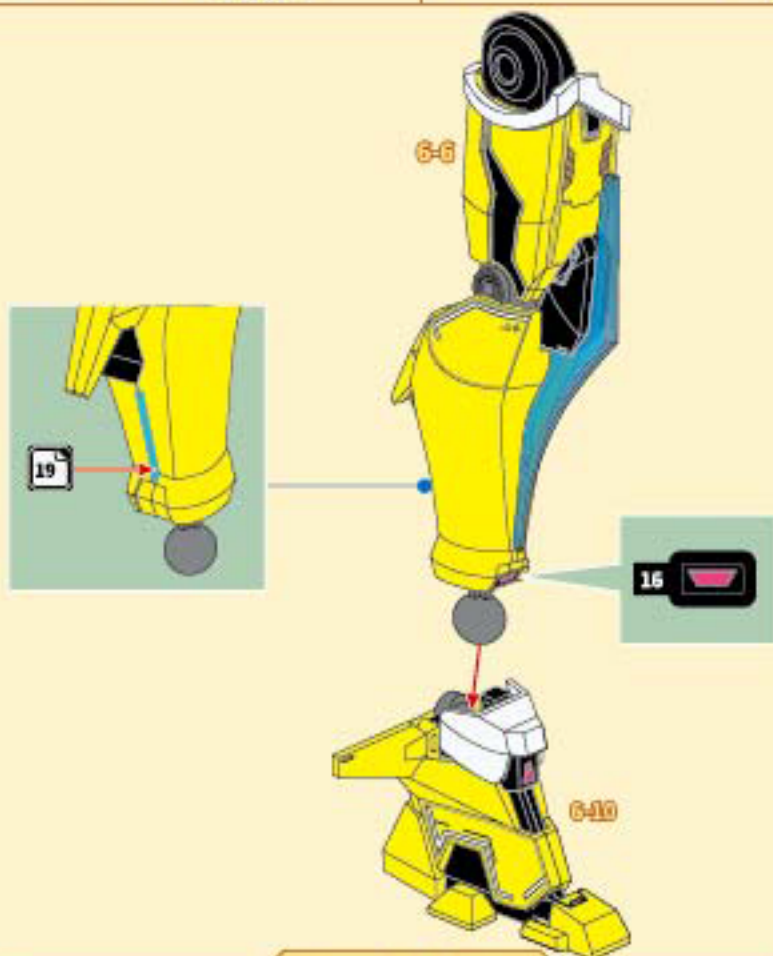

7 左脚组件

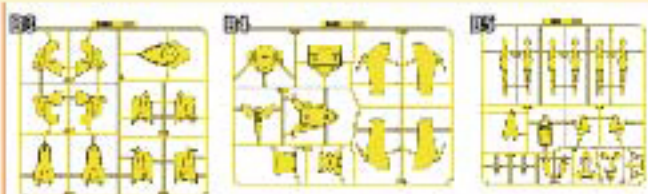

所需板件

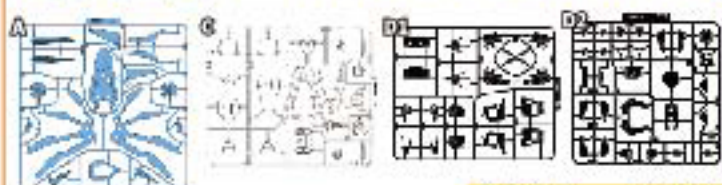

板件编码 X1 X

零件编码 X1 X

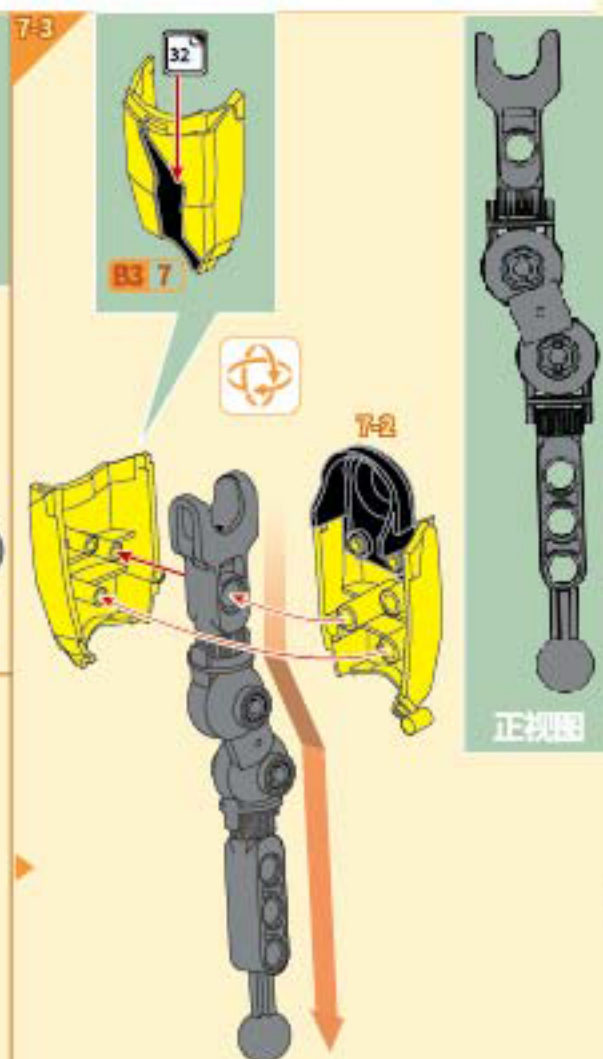
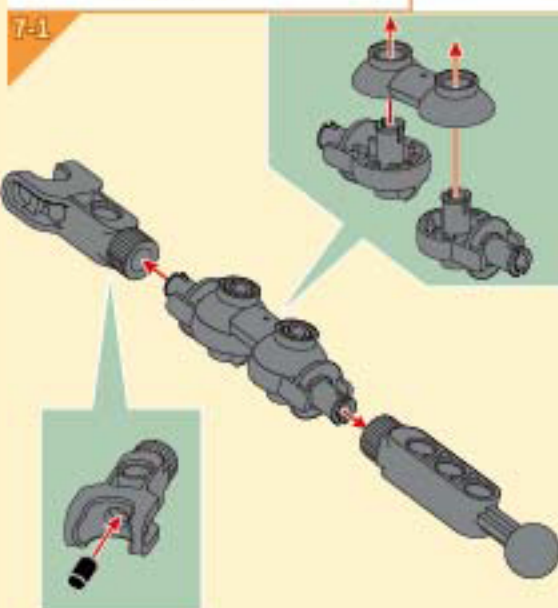

7-4

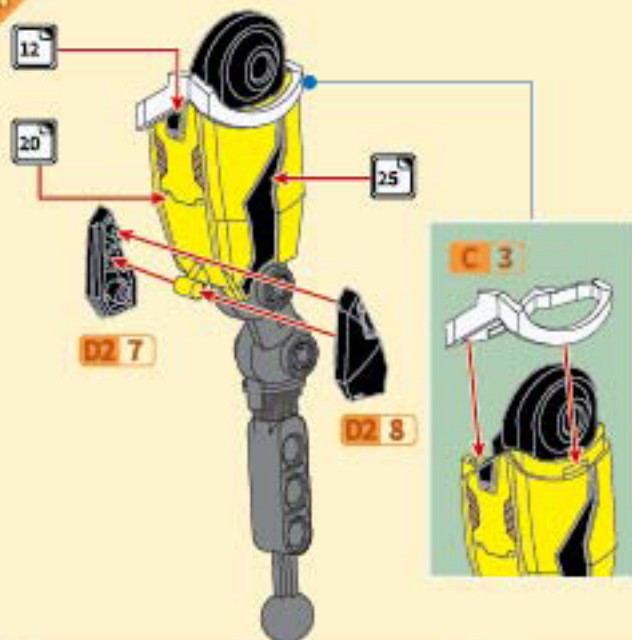

7-5

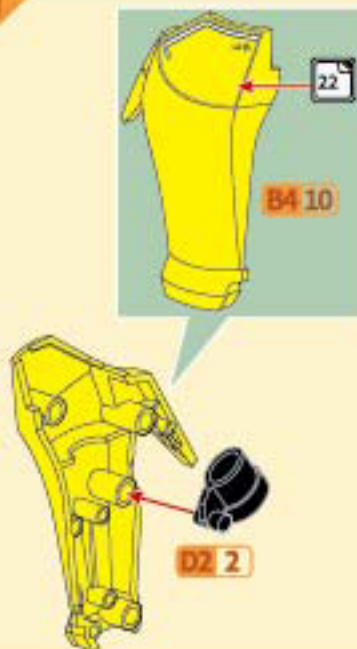

7-6

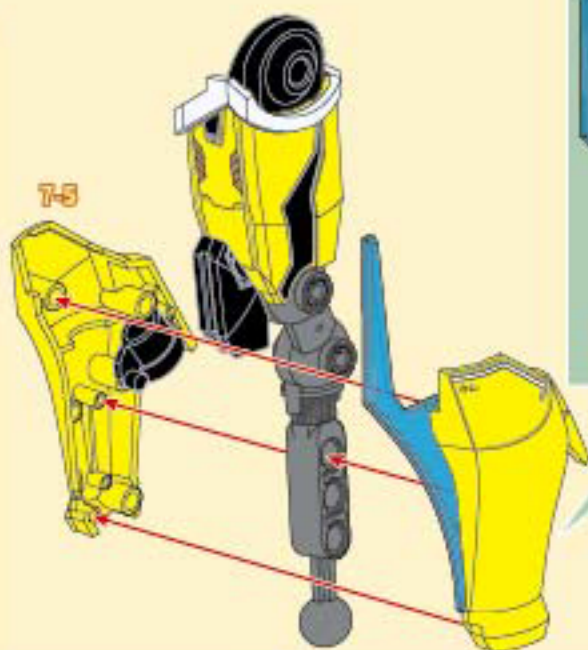
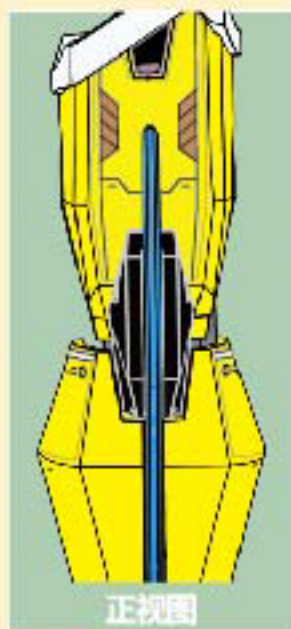

7-7

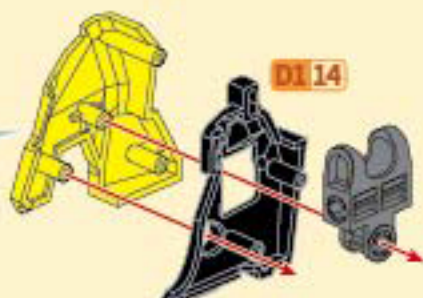

7-8

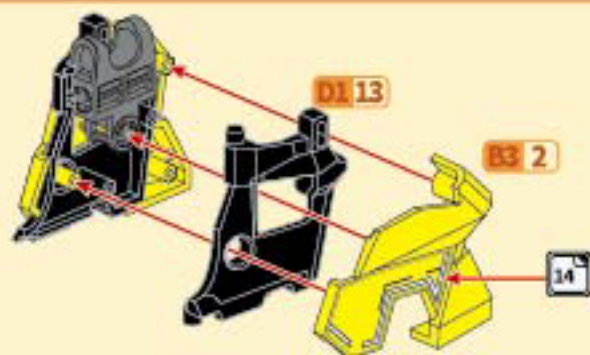

7-9

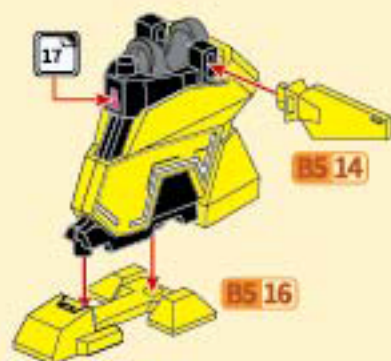

7-10



7-11

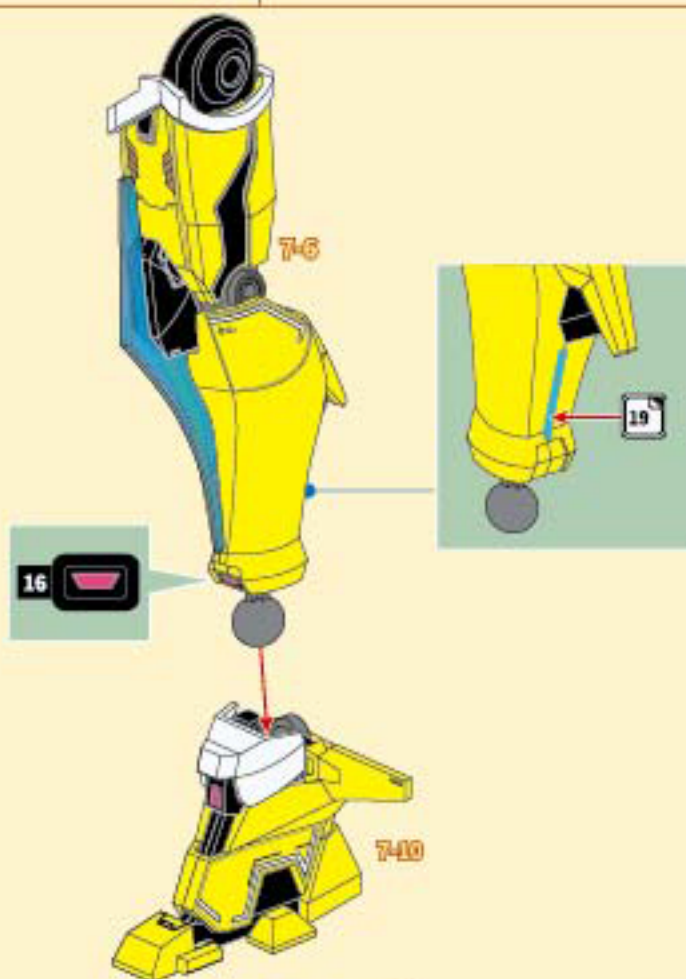

8 翅膀组件

所需板件

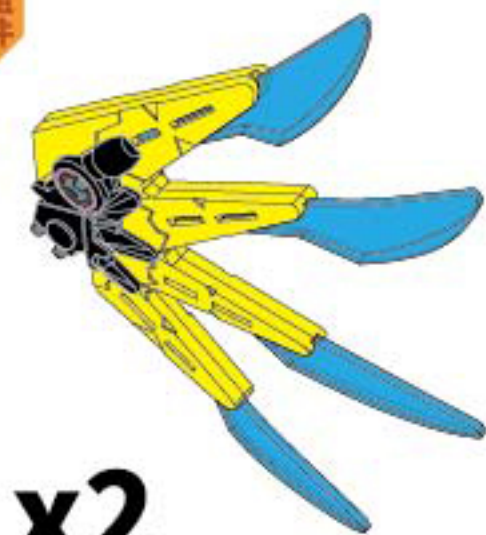

x2

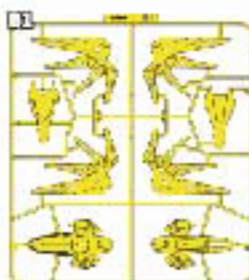
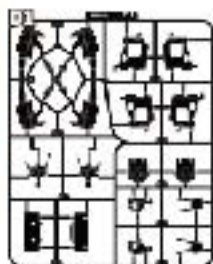

板件编码 零件编码

A1 X

8-1

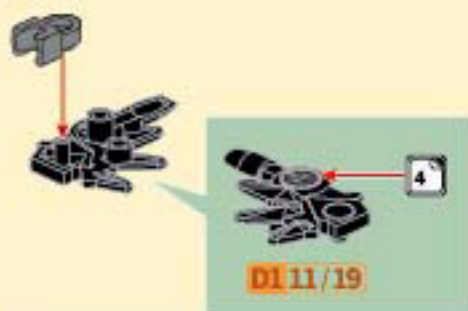

D1 11/19

8-2



B1 3/6

8-3

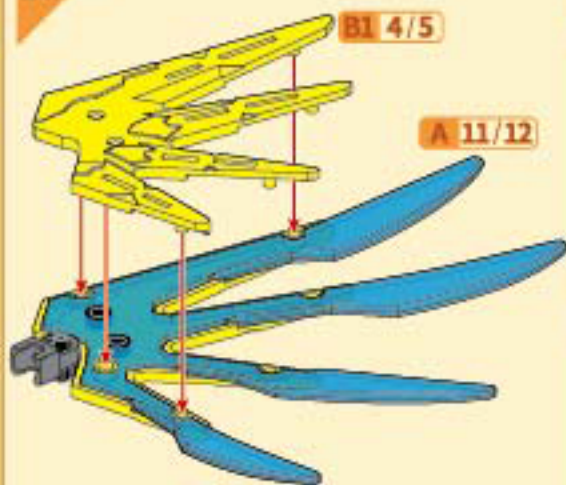

B1 4/5

A 11/12

8-4

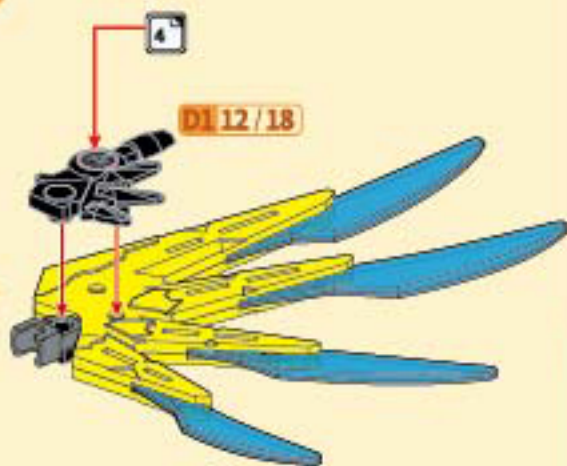

D1 12/18

9 武器组件

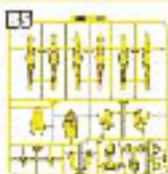

所需板件

板件编码 A1 X
零件编码

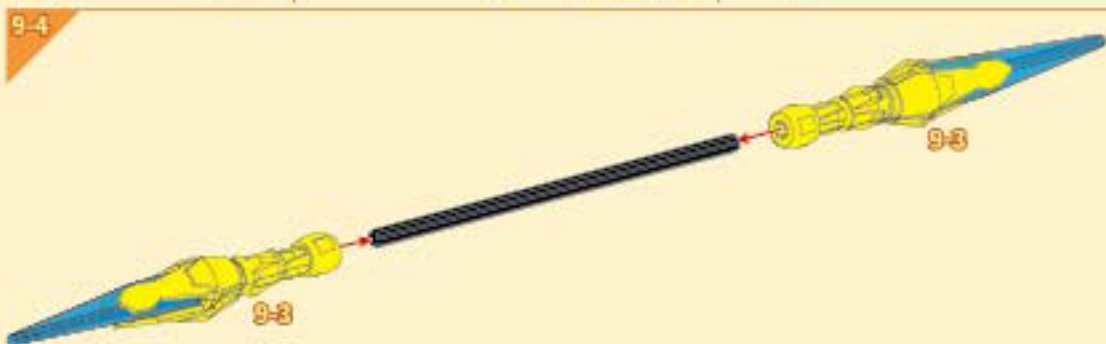
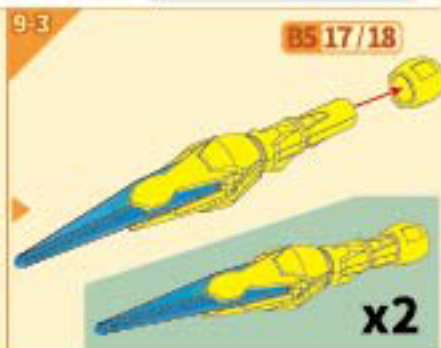
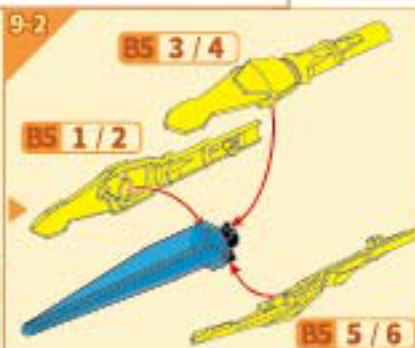
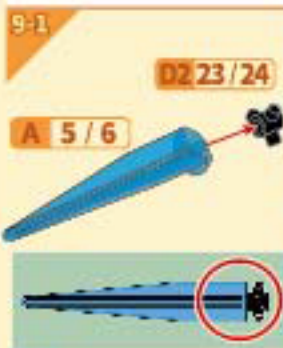

10 裙甲组件

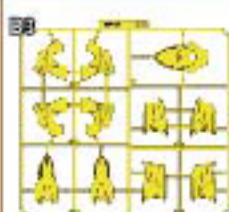

所需板件

板件编码 A1 X
零件编码

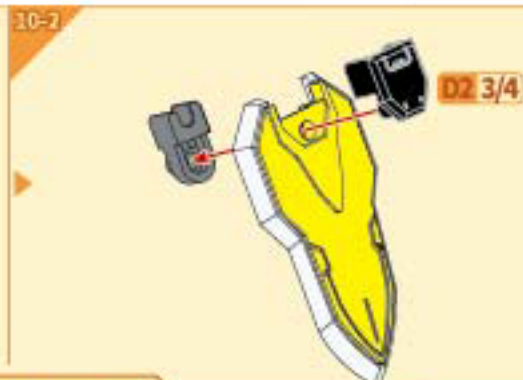
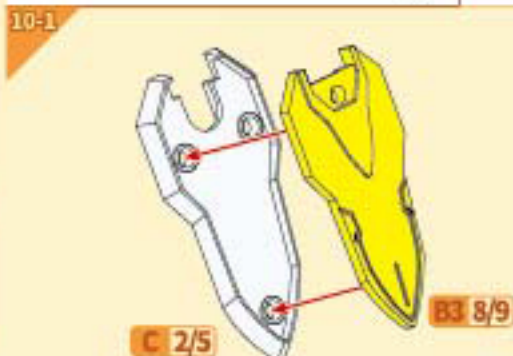

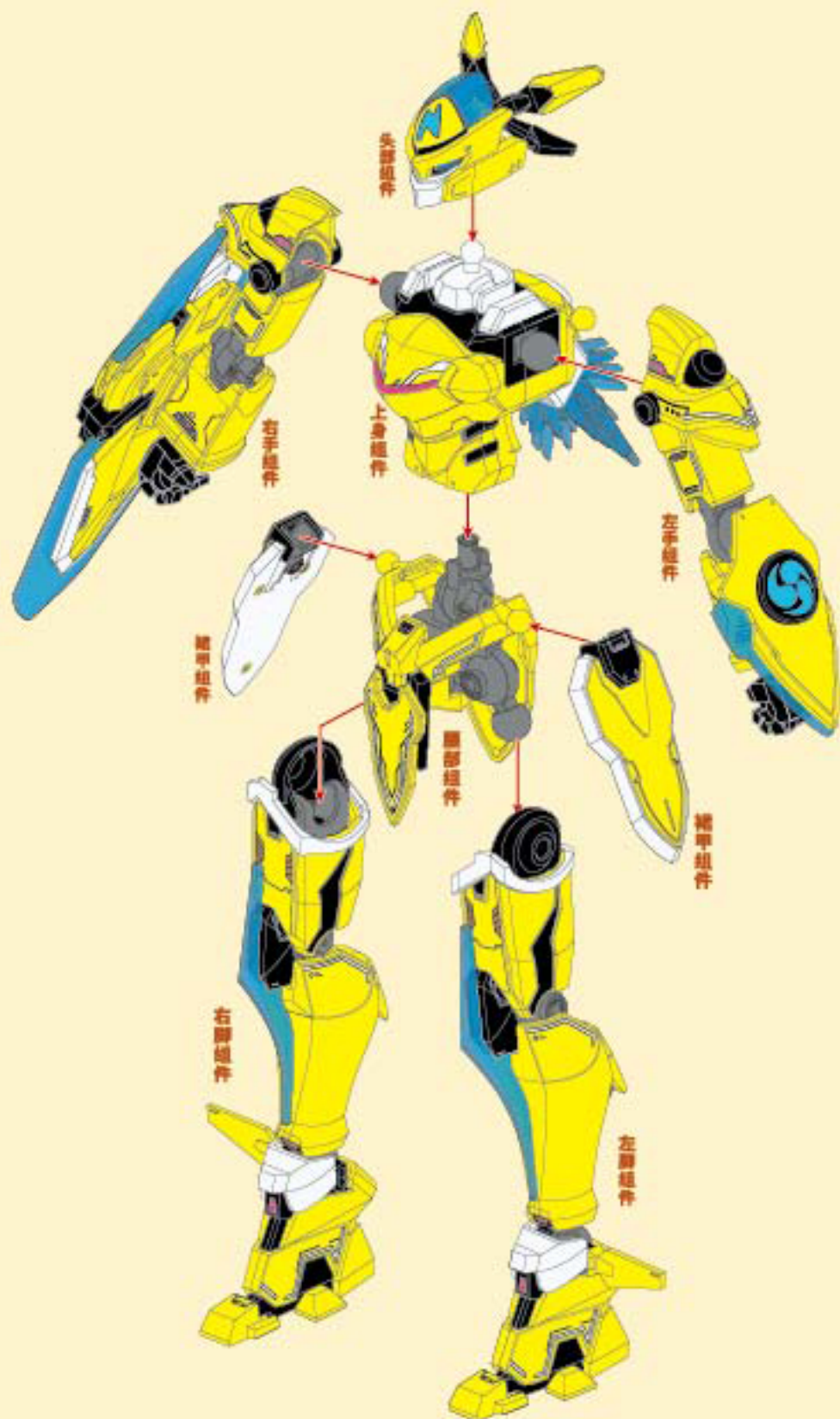

完成



翅膀组件

翅膀组件

武器组件

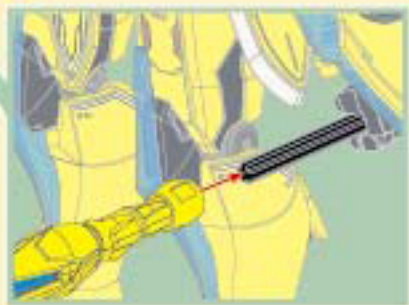

盾牌扩展玩法

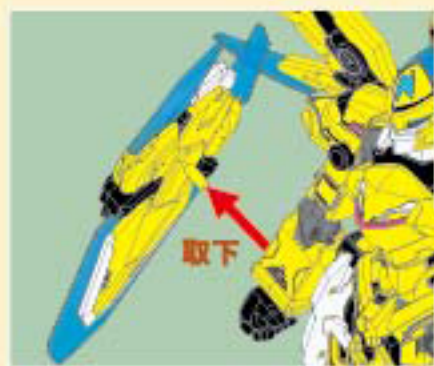

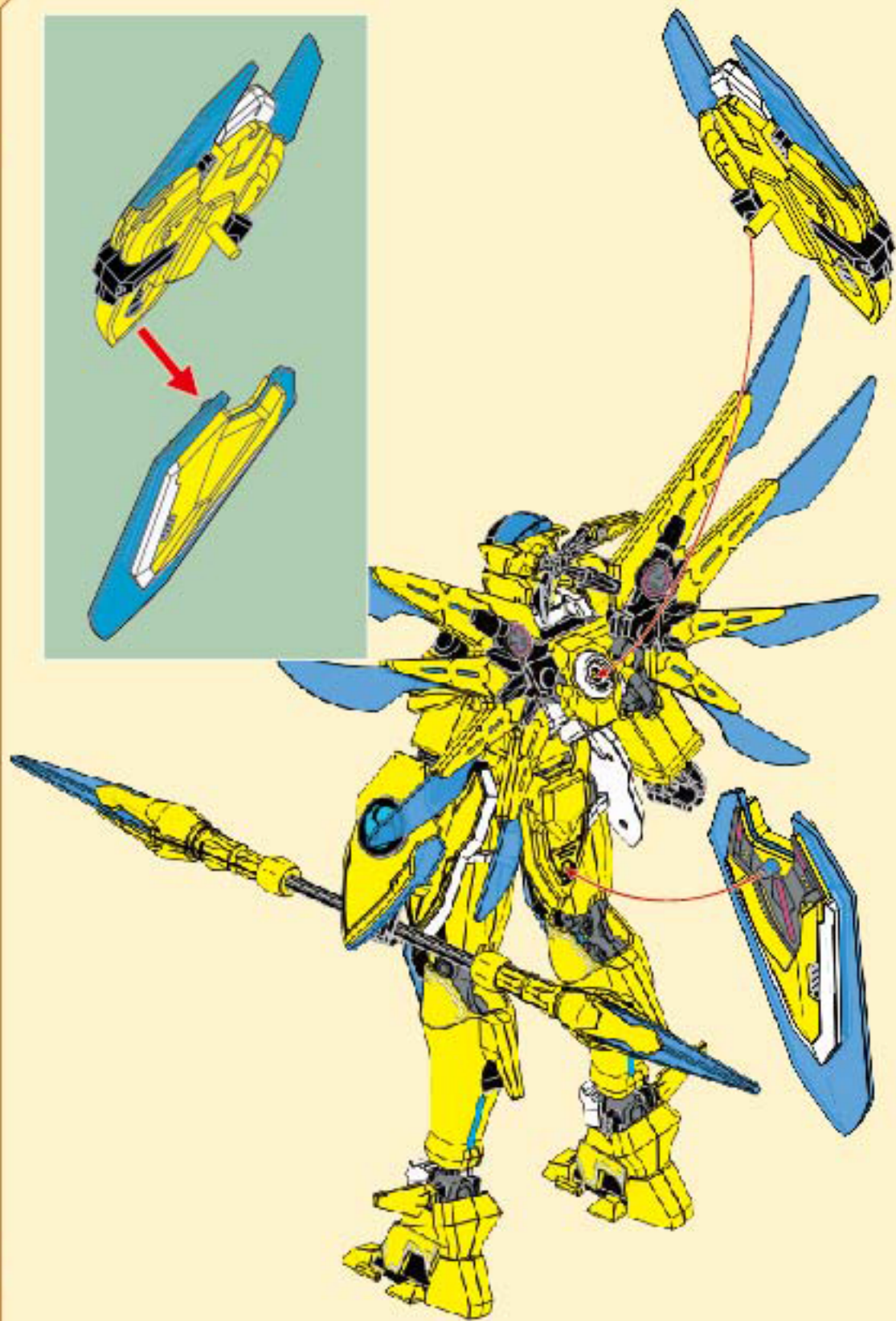

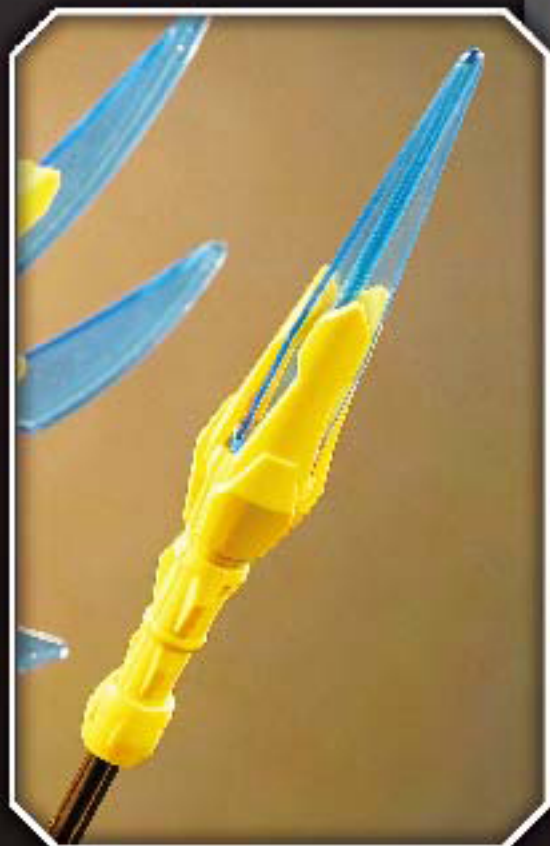
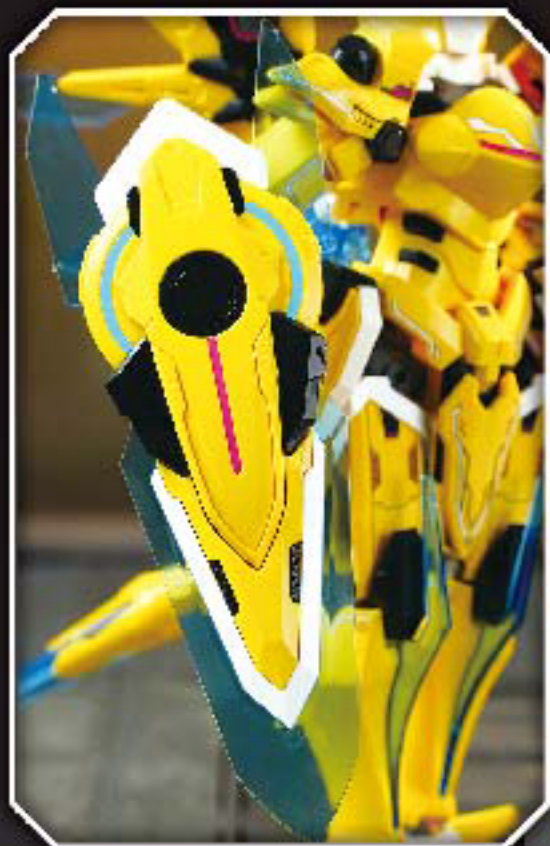

银河封神纪

V1.0