



Combat Zones Series

1406-2

Ages: 6+

PCS: 78



F/A-18 FIGHTER

**A7**

- 2x [black 1x1 pin]
- 2x [black 1x2 brick]
- 2x [black 1x3 brick]
- 2x [black 1x4 brick]
- 2x [black 1x6 brick]
- 2x4 [black 2x4 brick]

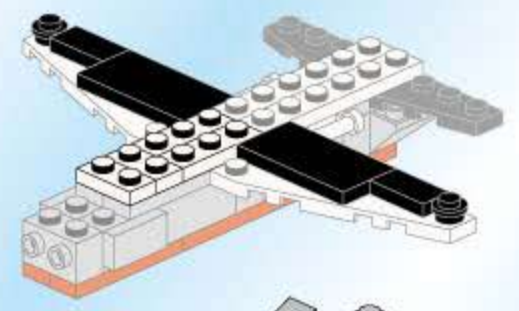

**A8**

- 2x [grey 1x1 brick]
- 2x [grey 1x2 brick]
- 2x [grey 1x3 brick]
- 1x [grey 1x4 brick]

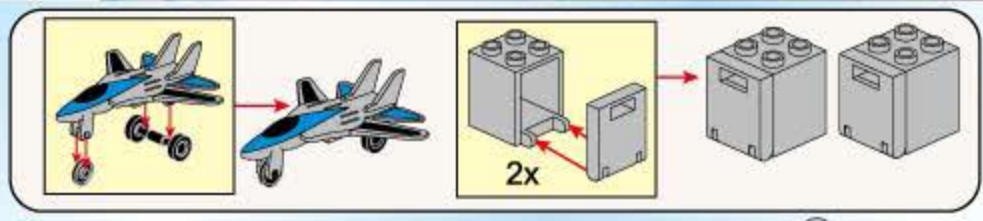
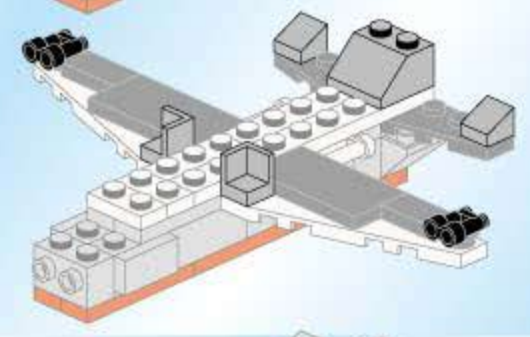

**A9**

- 1x [grey 1x1 brick]
- 1x [black 1x1 brick]
- 1x [black 2x8 brick]
- 2x8 [black 2x8 brick]

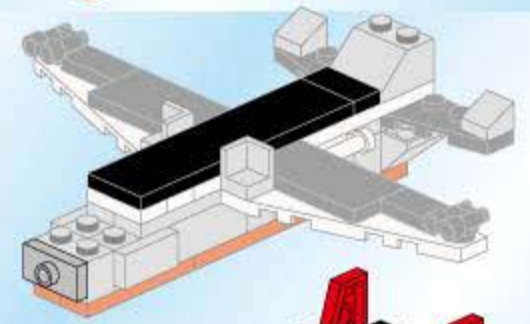

**A1**

- 1x [grey 1x1 brick]
- 2x [red 1x8 brick]
- 1x8 [red 1x8 brick]

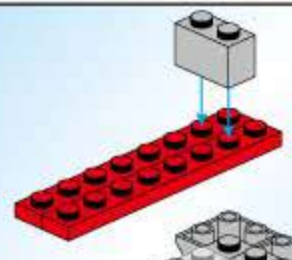

**A2**

- 1x [grey 1x1 brick]
- 2x [grey 1x2 brick]
- 1x [grey 1x3 brick]
- 2x [grey 1x4 brick]

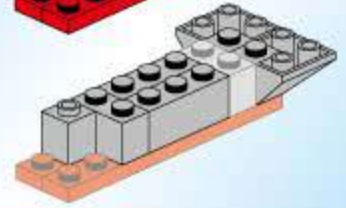

**A10**

- 1x [black 1x1 brick]
- 1x [blue 1x1 curved brick]
- 1x [red 1x2 brick]
- 1x [red 1x3 brick]

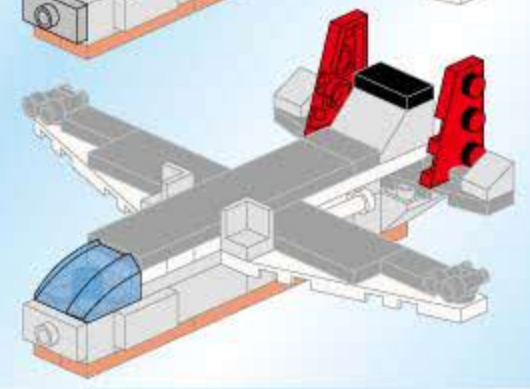

**A3**

- 2x [red 1x2 brick]
- 1x [grey 1x2 brick]
- 1x [grey 1x3 brick]

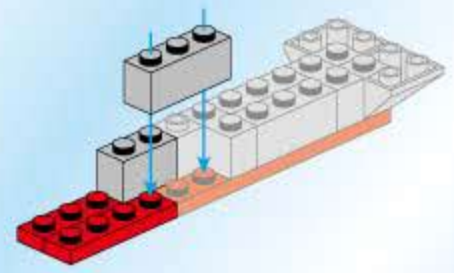

**A11**

- 1x [grey 1x1 pin]
- 1x [black 1x1 pin]
- 1x [grey 1x1 cone]

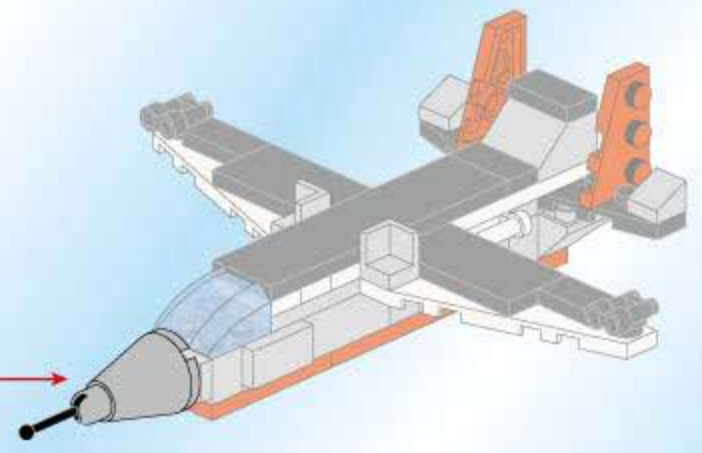

**A4**

- 2x [grey 1x1 brick]
- 1x [grey 1x2 brick]
- 2x [grey 1x3 brick]
- 1x [black 1x4 brick]
- 3x [grey 1x4 brick]
- 1x [black 1x6 brick]

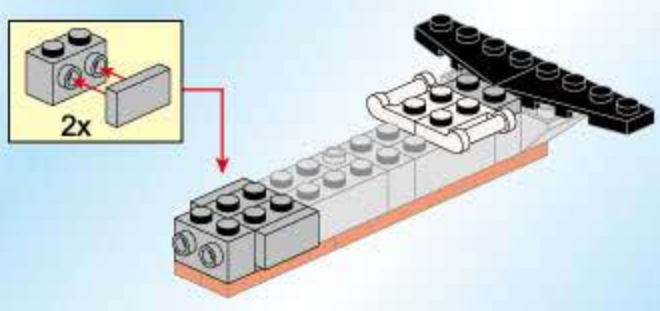

**A5**

- 1x [grey 1x10 brick]
- 1x [grey 1x10 brick]

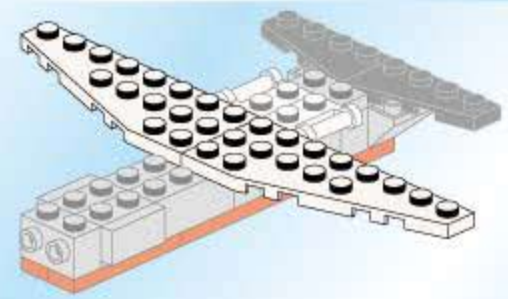

**A12**

- 2x [grey 1x1 brick]
- 4x [grey 1x2 brick]
- 2x [grey 1x3 brick]
- 3x [grey 1x4 brick]
- 2x [grey 1x5 brick]
- 2x [grey 1x6 brick]

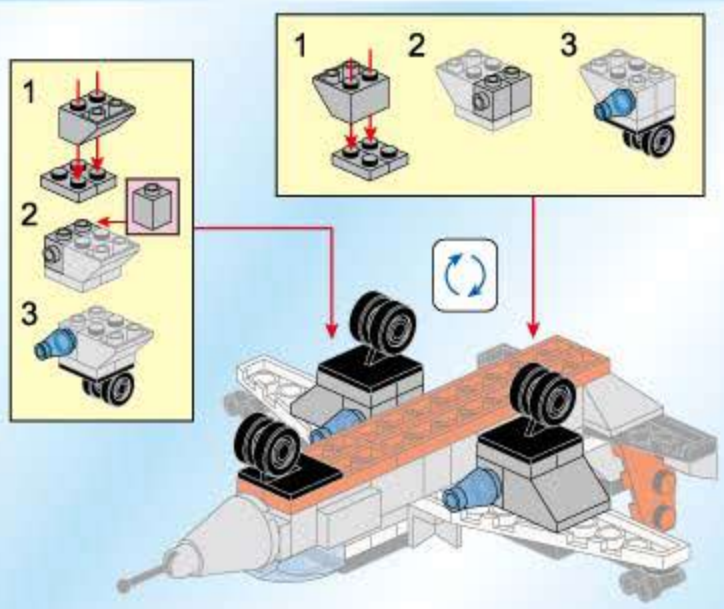

**A6**

- 2x [grey 1x1 brick]
- 2x [grey 1x2 brick]

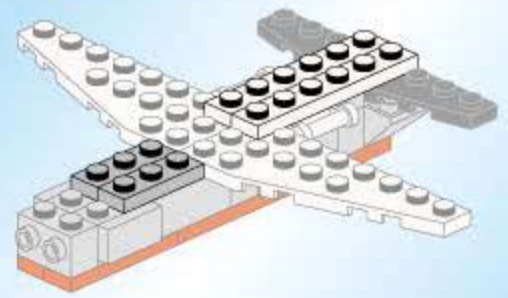



Deformation  
Directly



B6

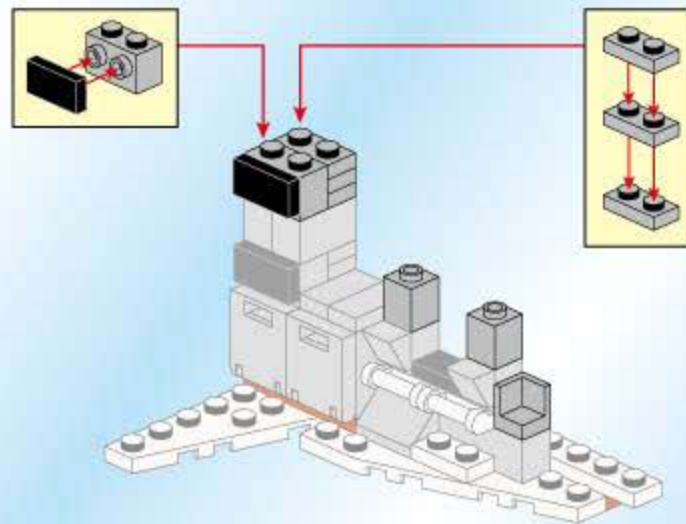

B1

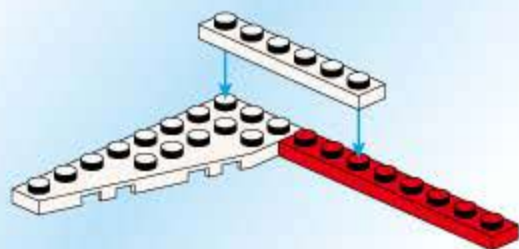
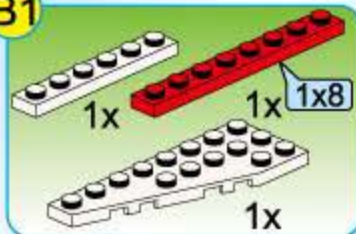

B2

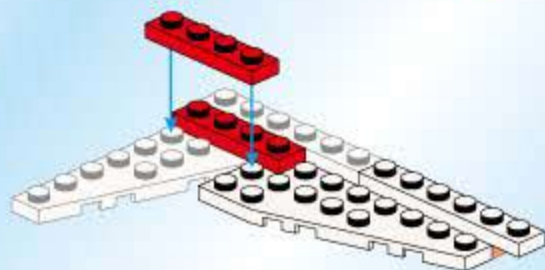
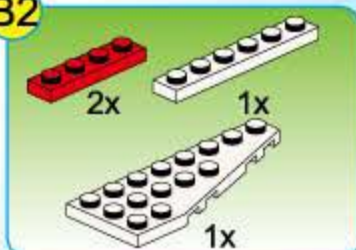

B7

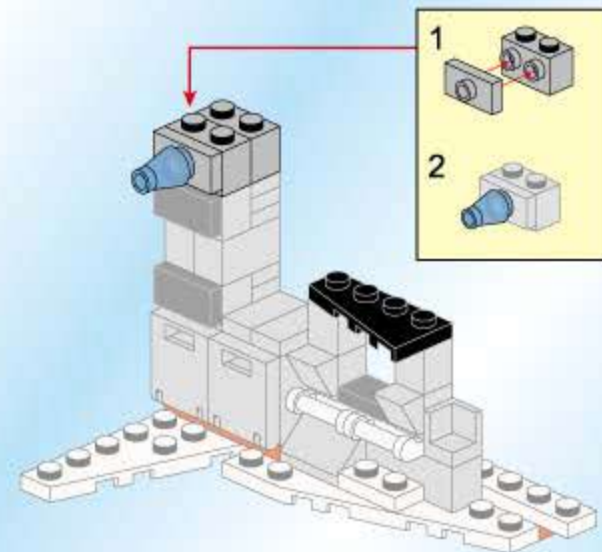
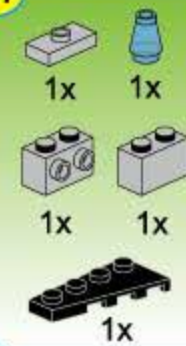

B3

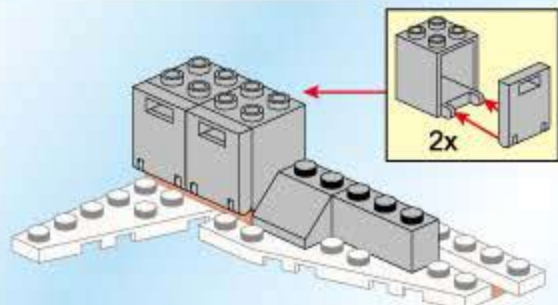
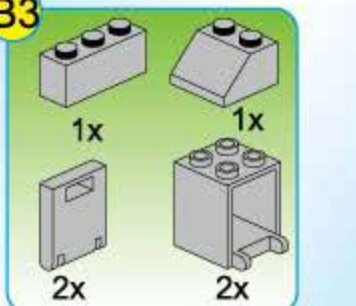

B4

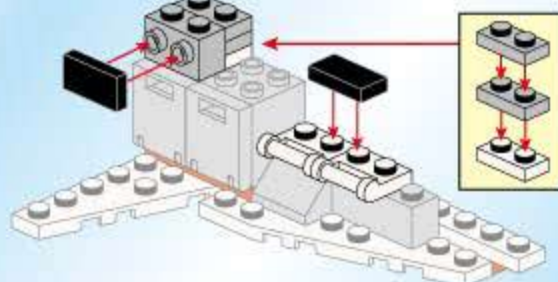
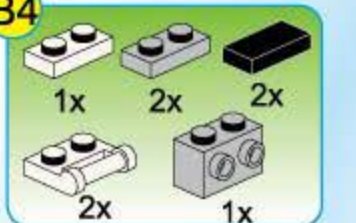

B8

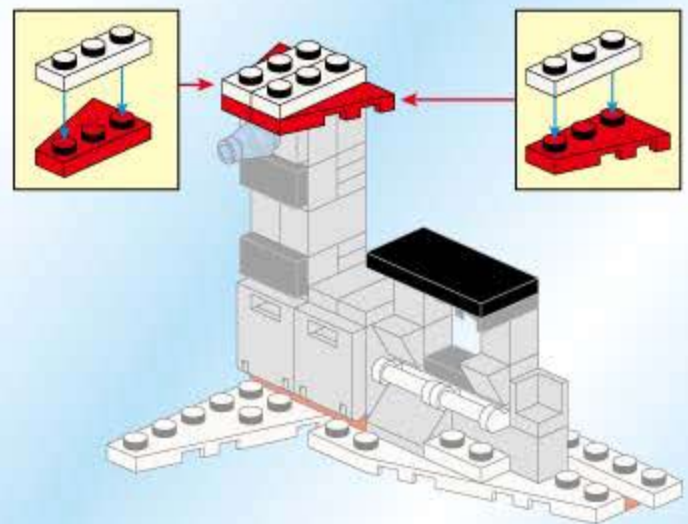
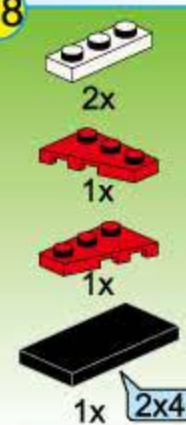

B5

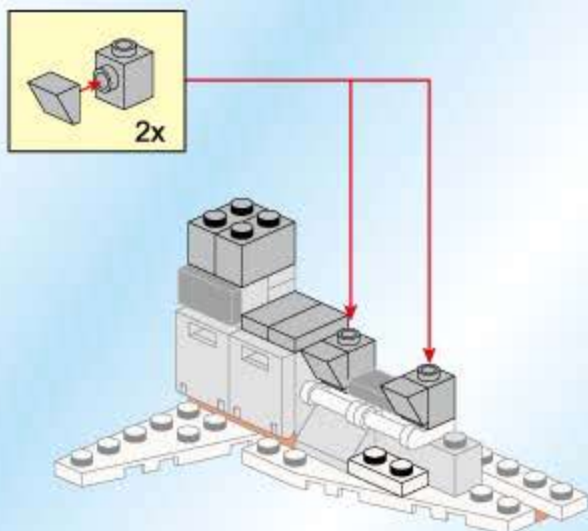
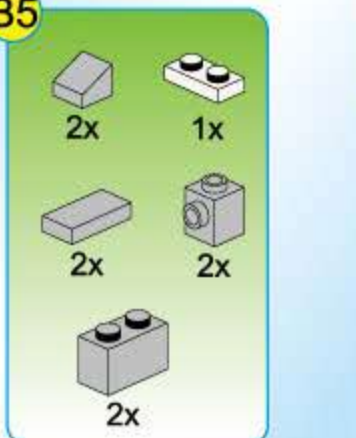

B9

