

**CombatZones**  
SERIES

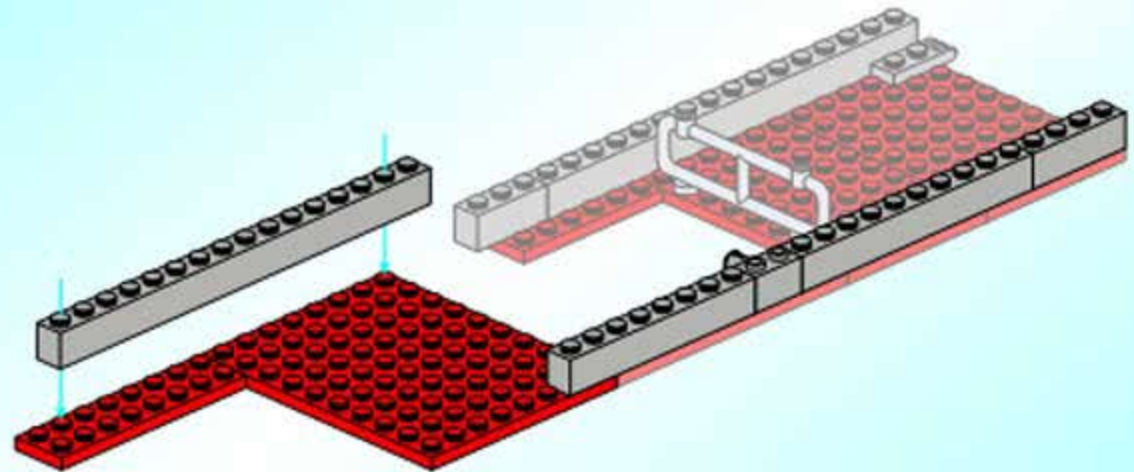

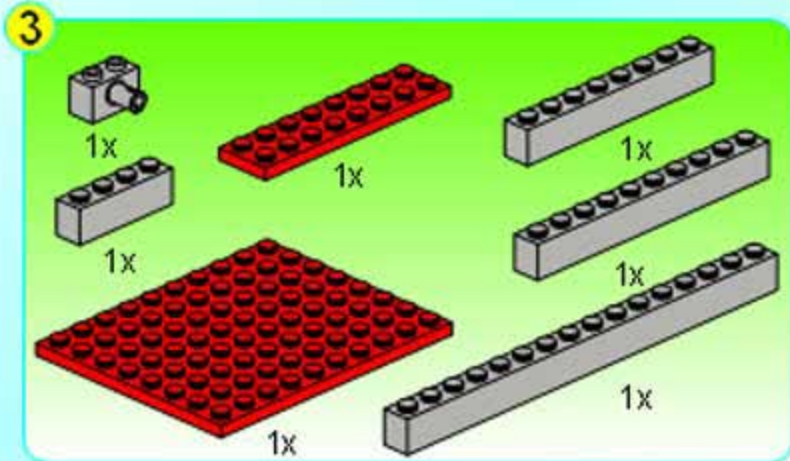

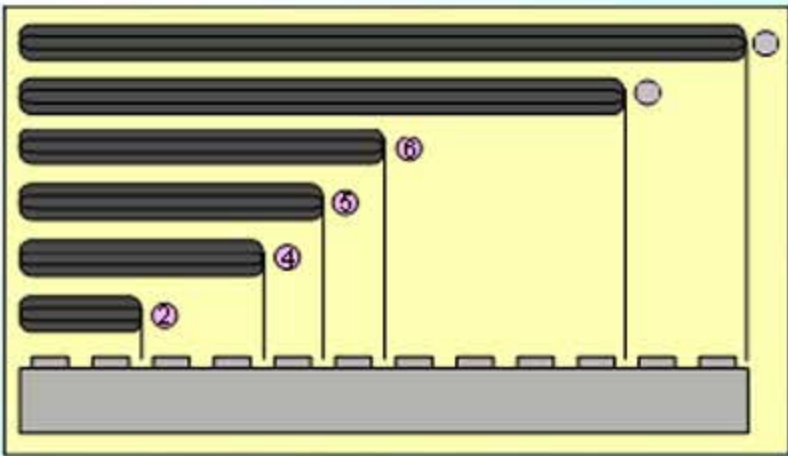

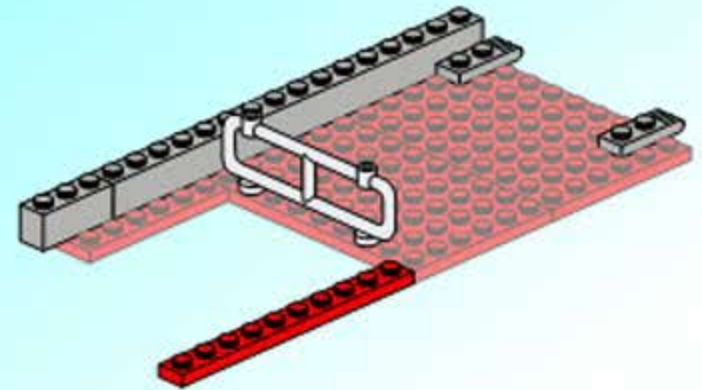
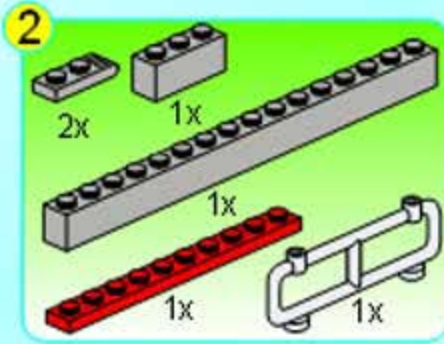
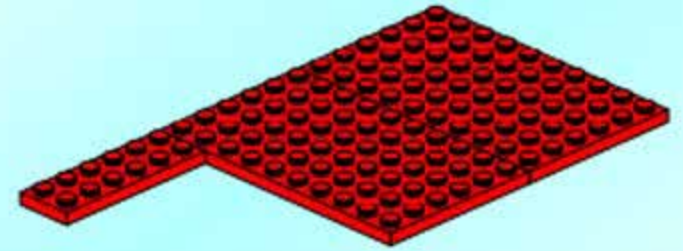
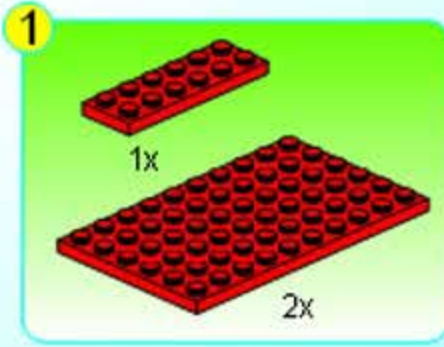
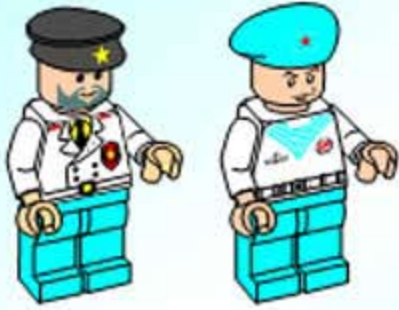





6

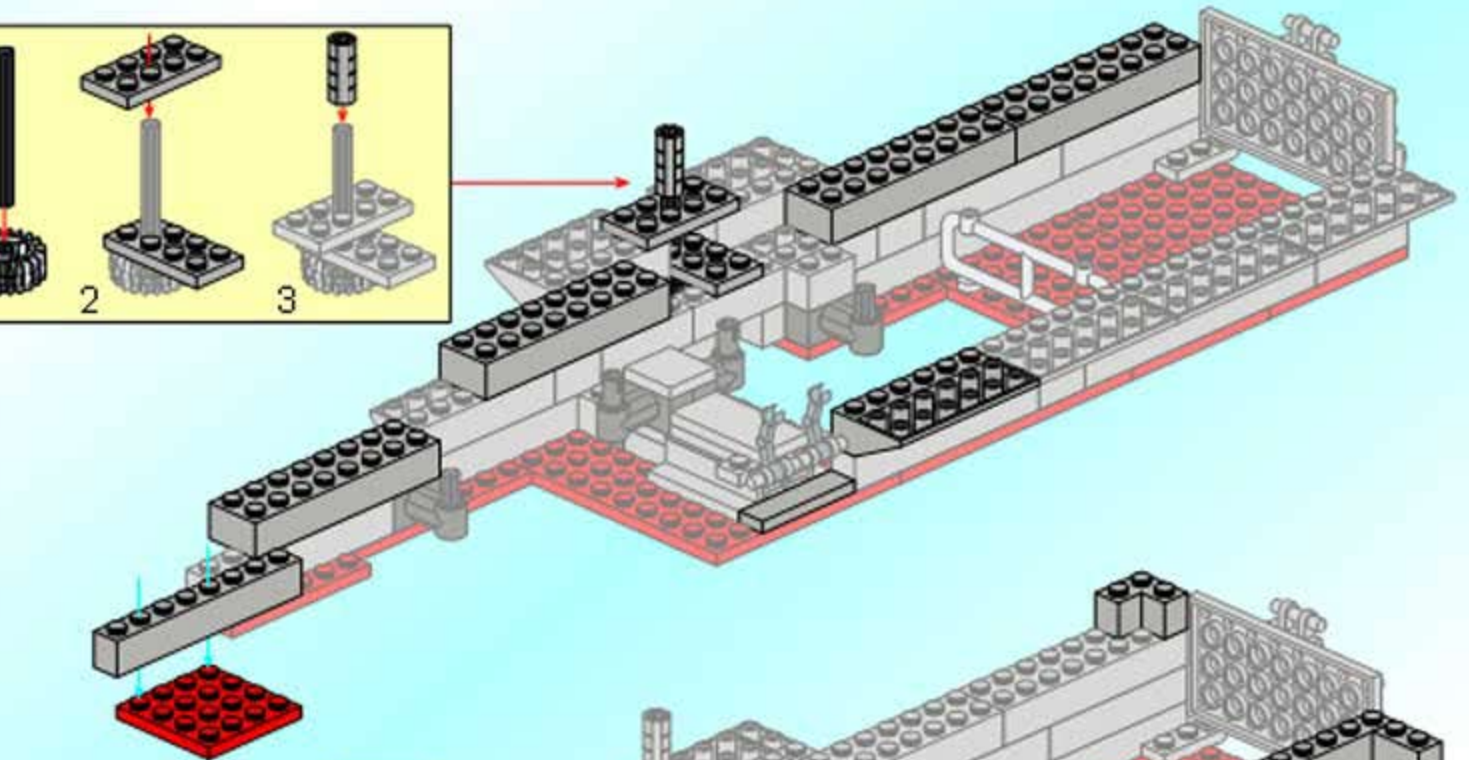
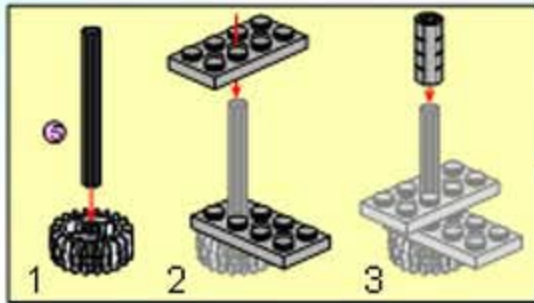
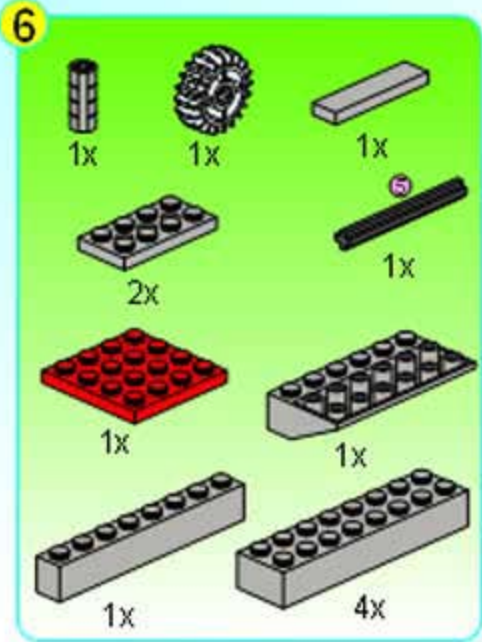

7

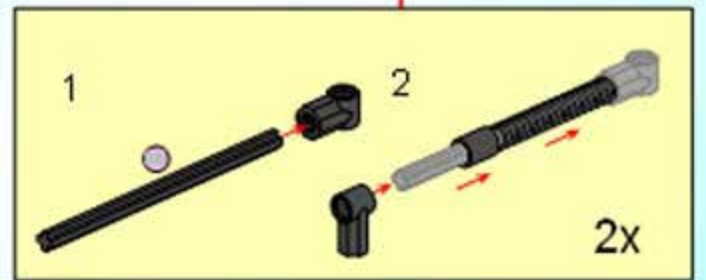
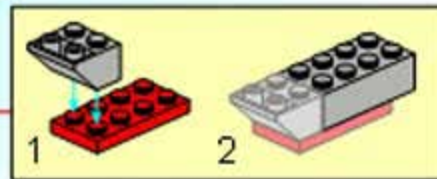
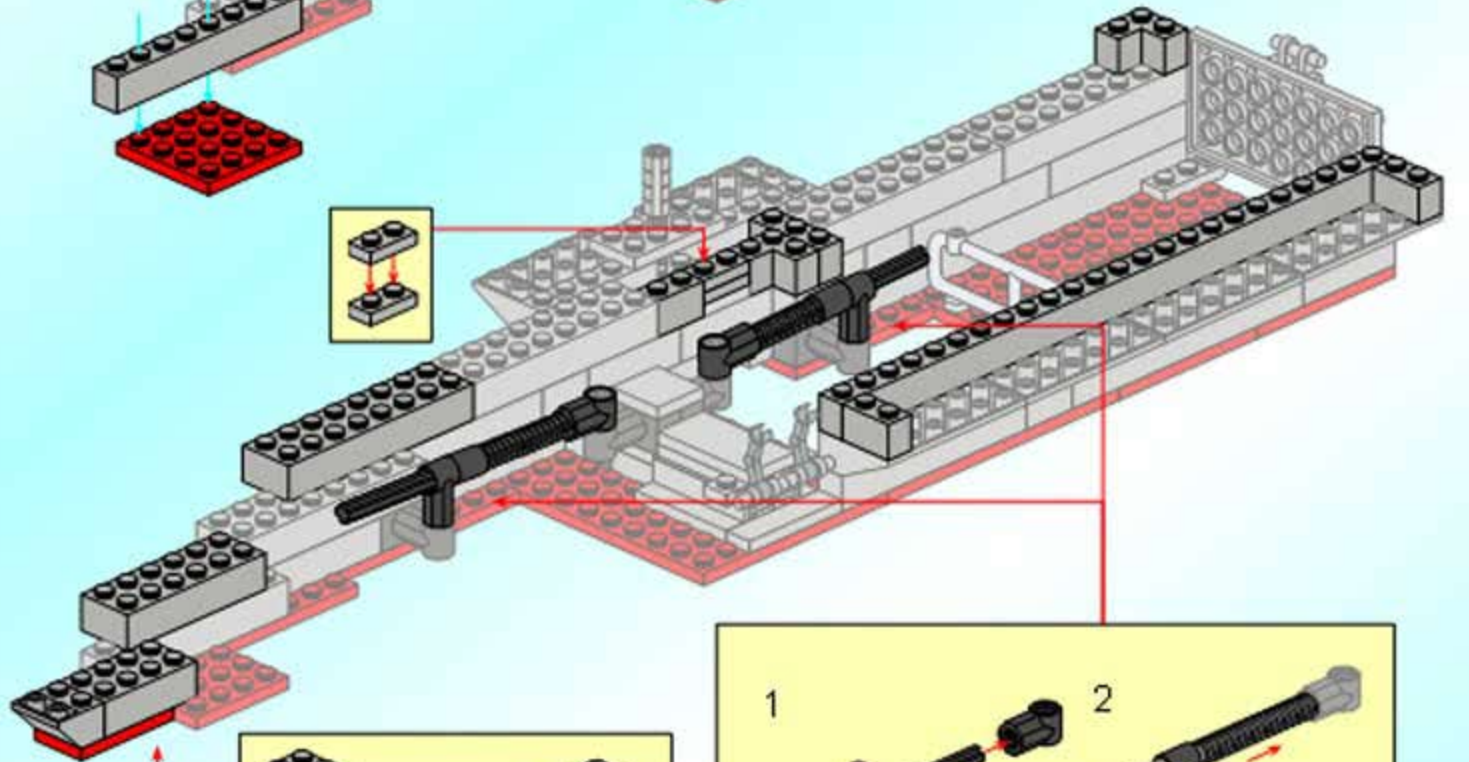
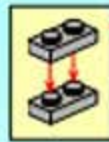
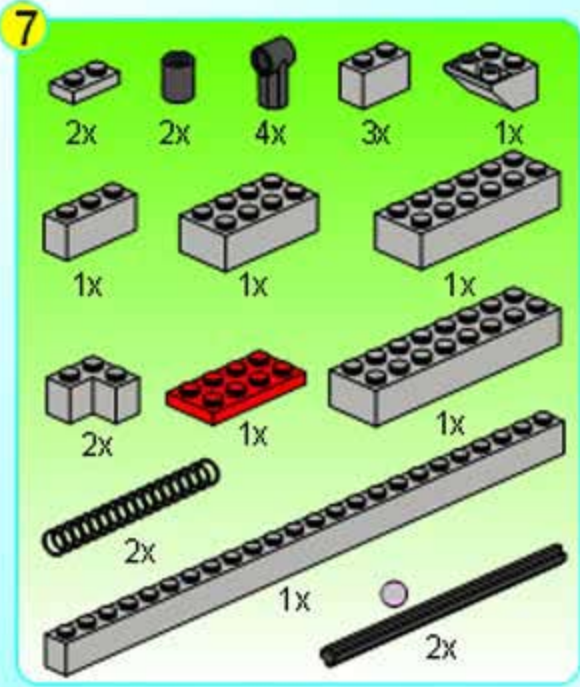

8

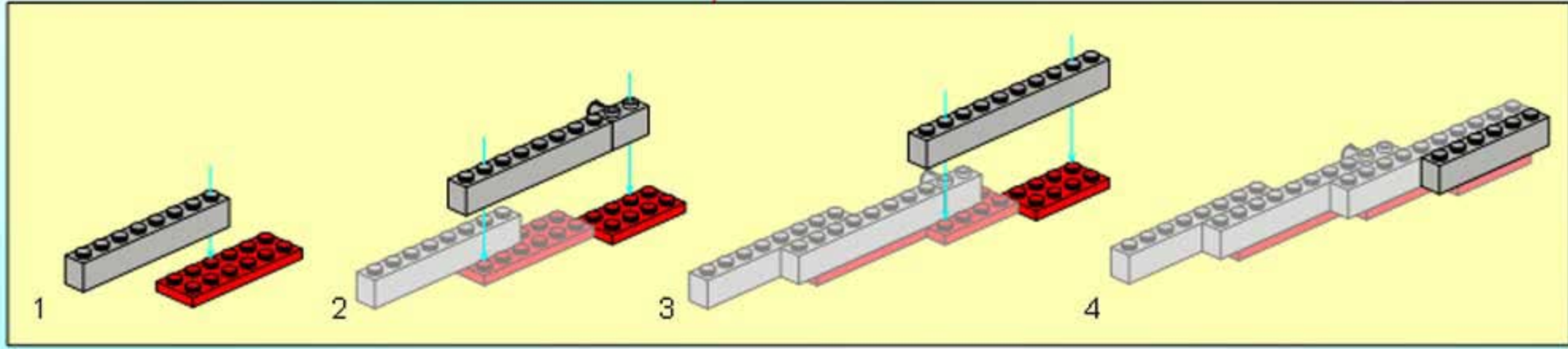
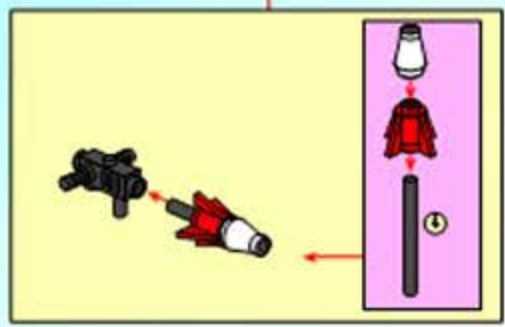
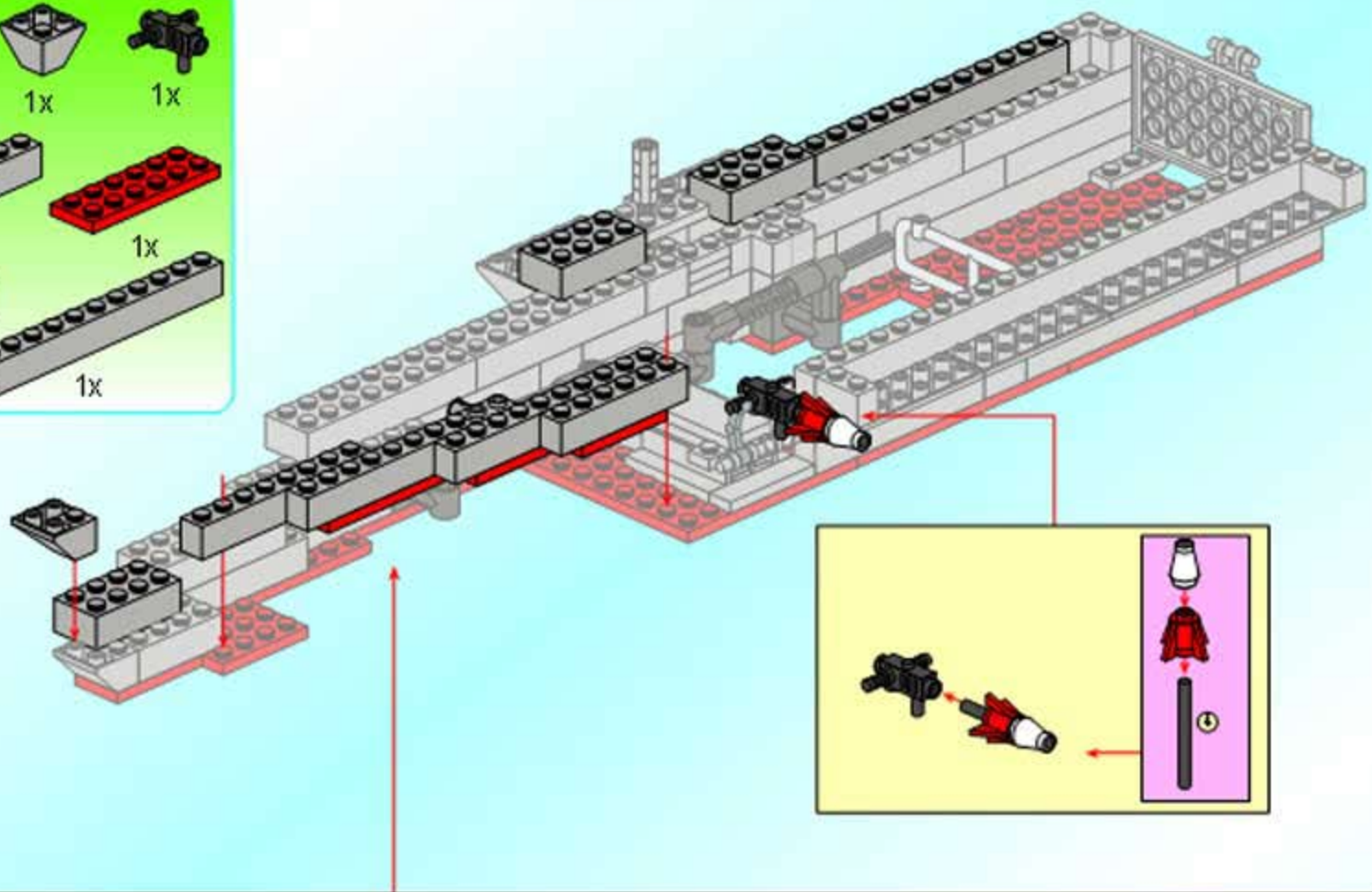
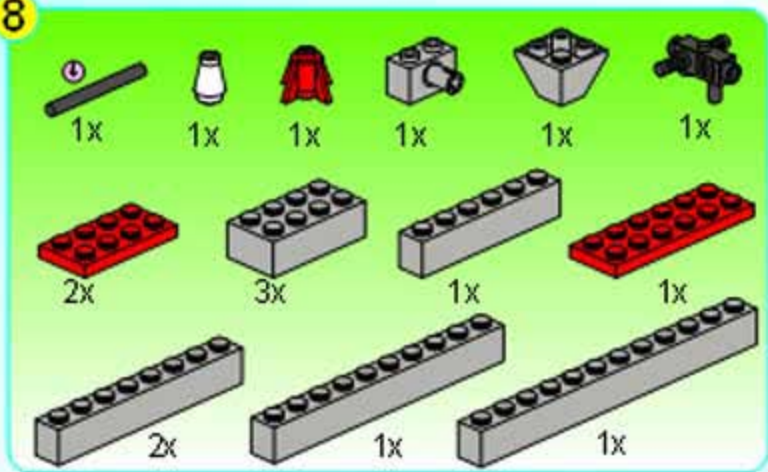



9

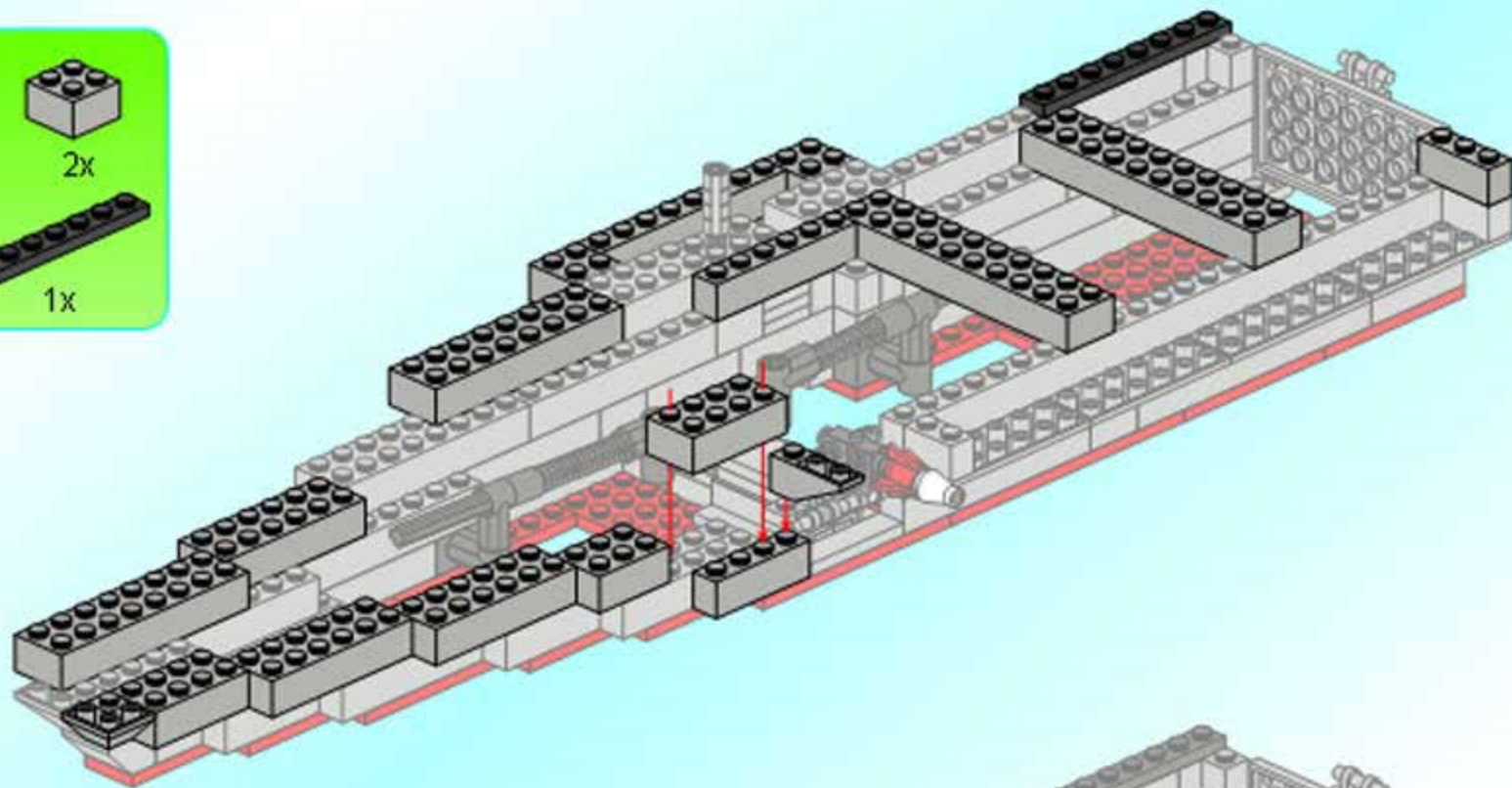
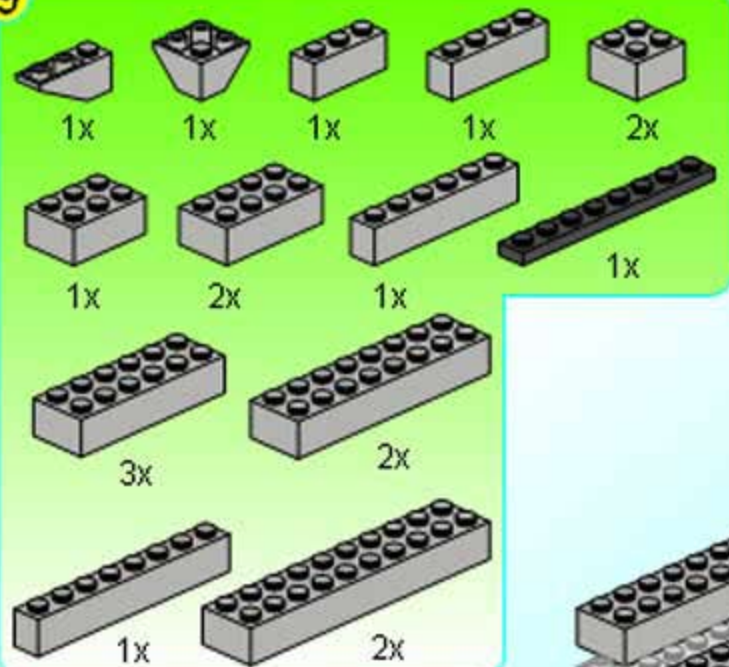

10

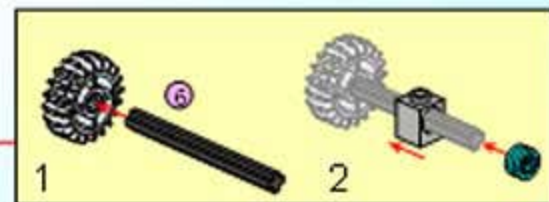
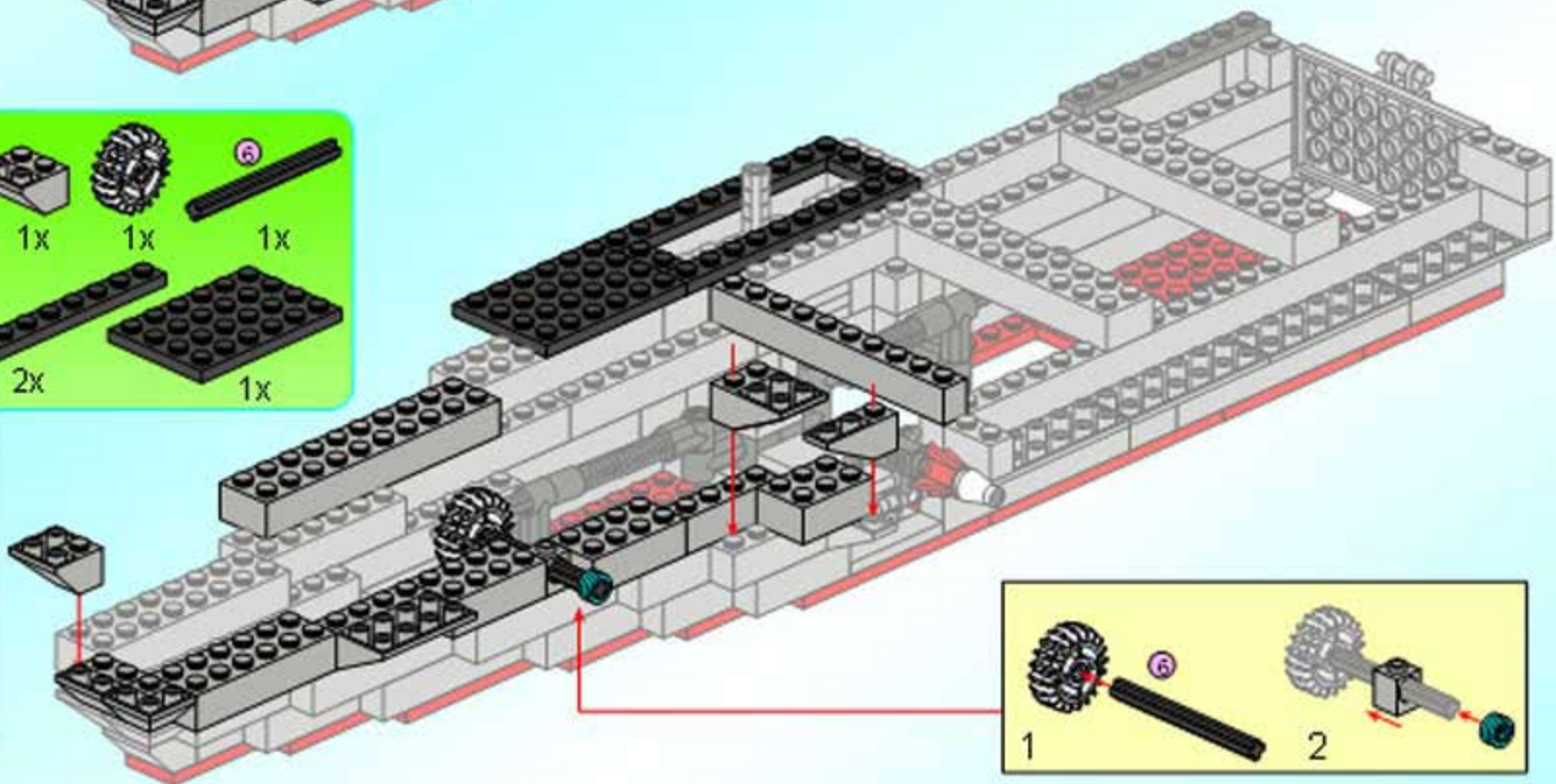
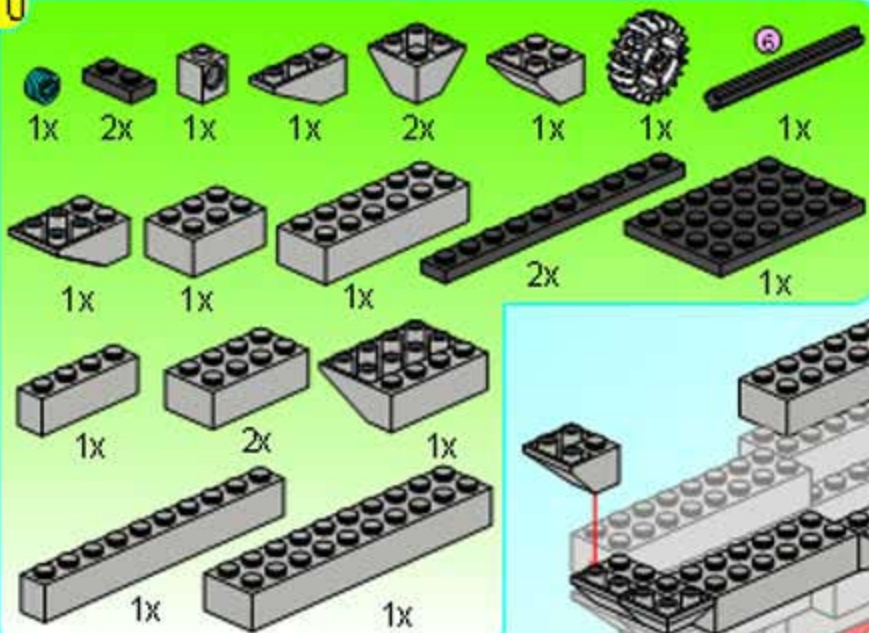



11

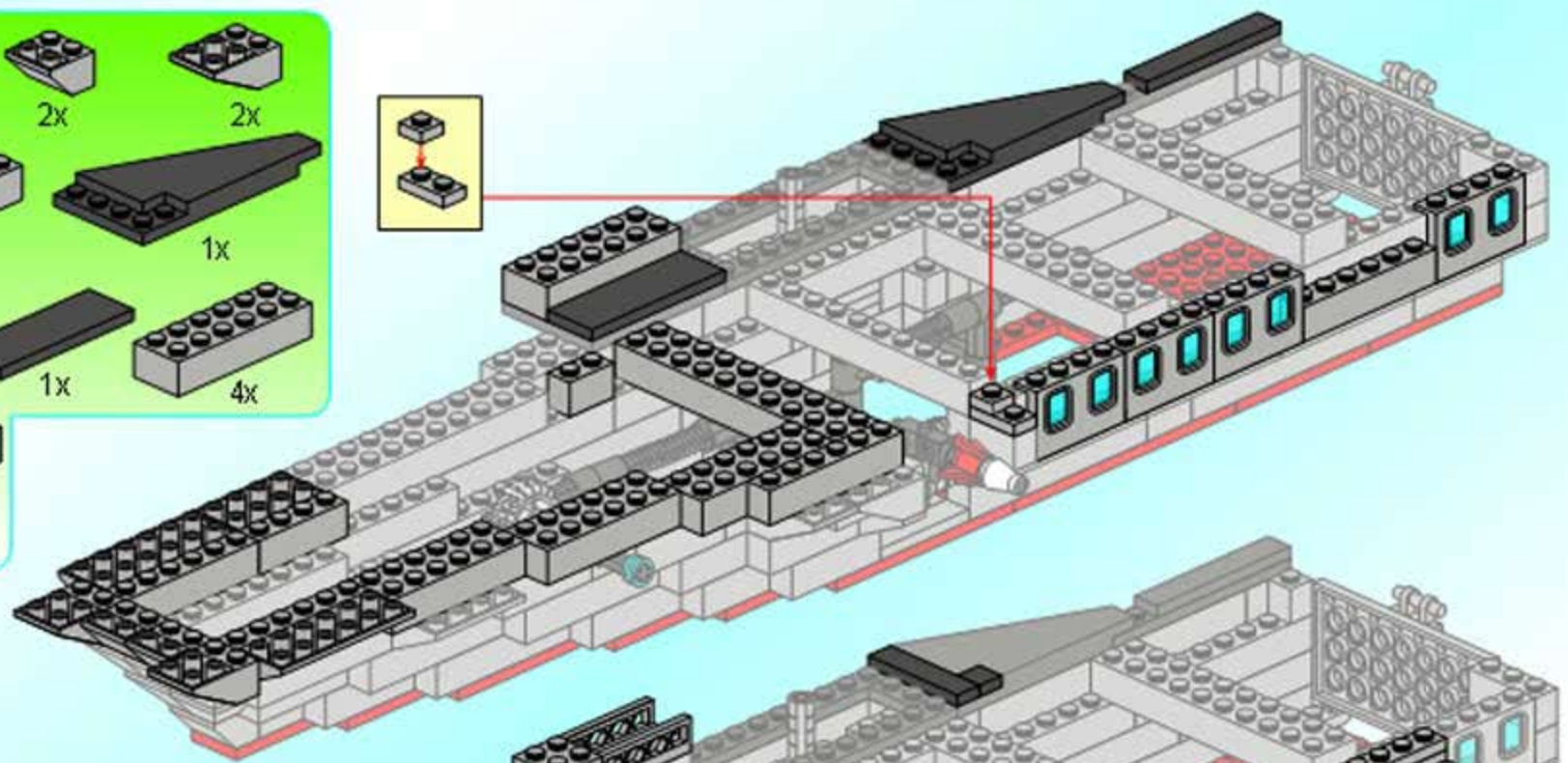
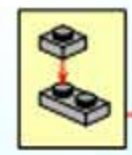
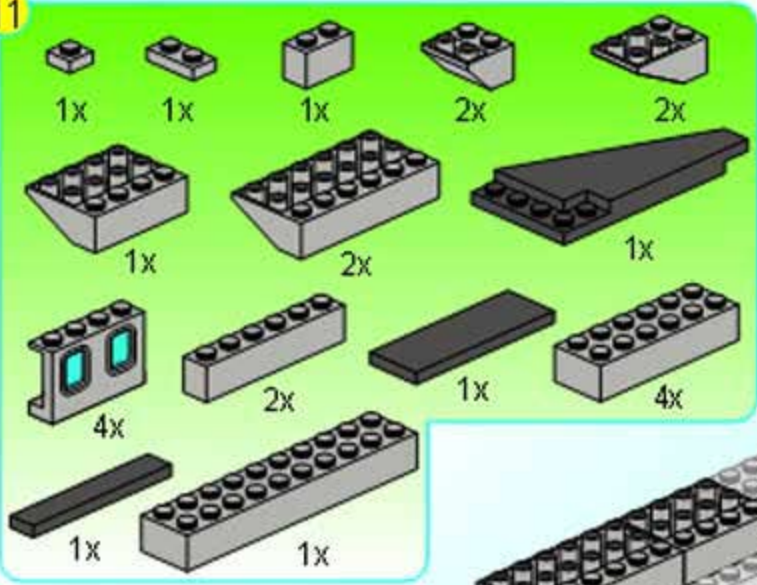

12

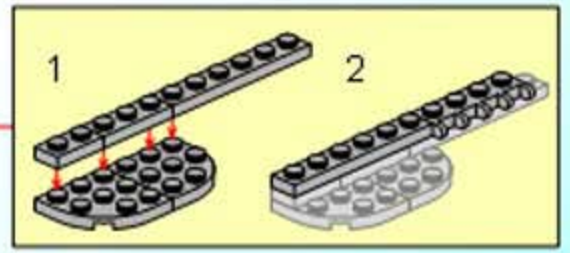
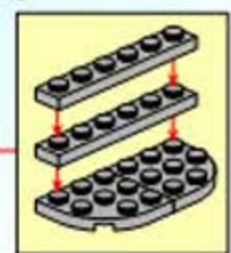
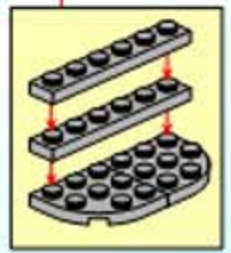
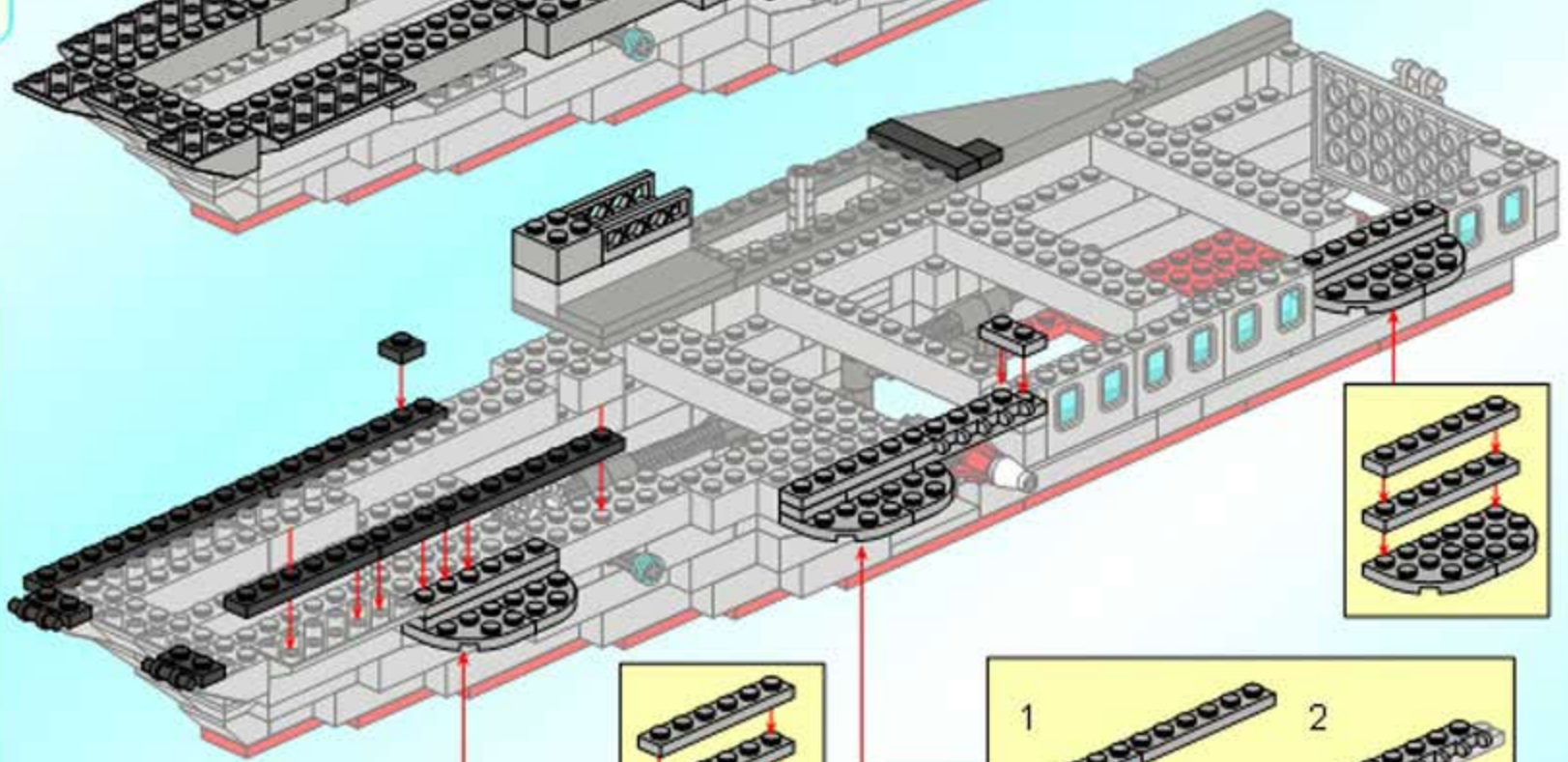
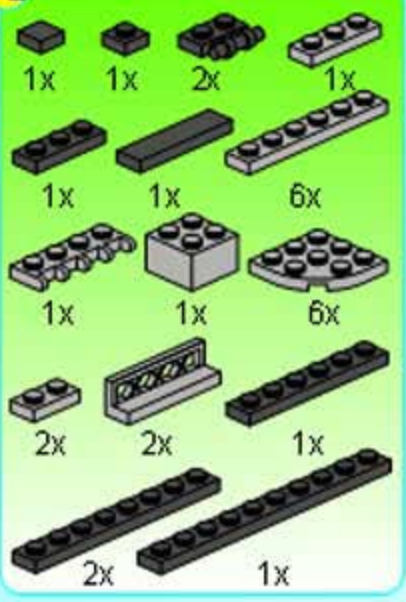







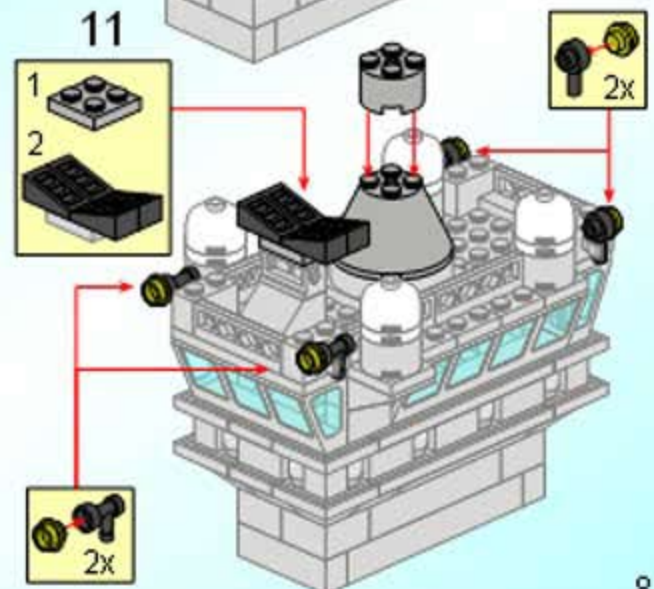
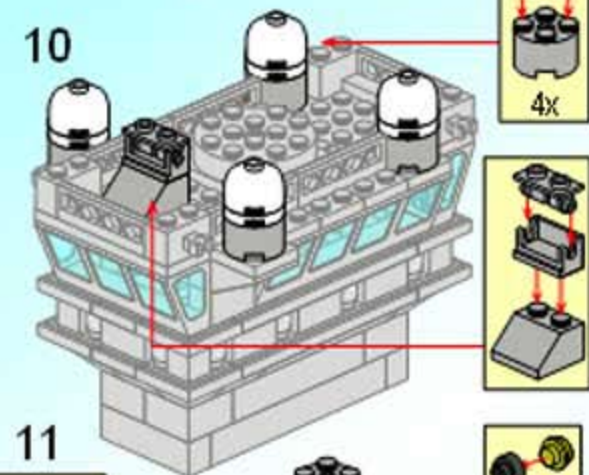
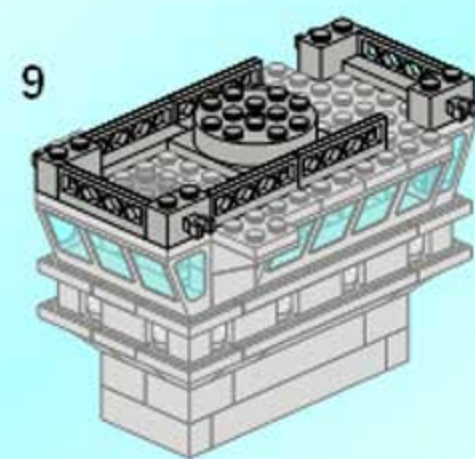
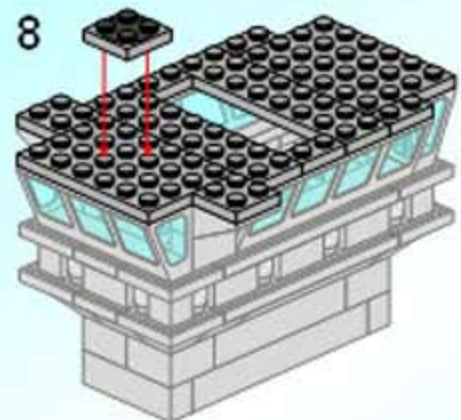
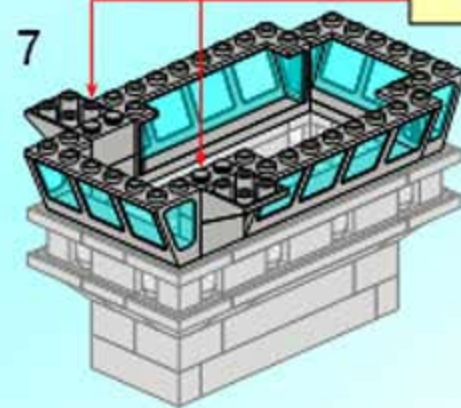
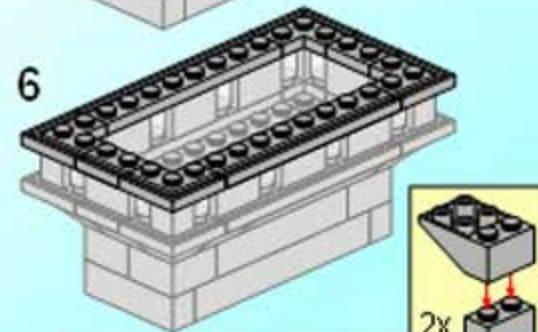
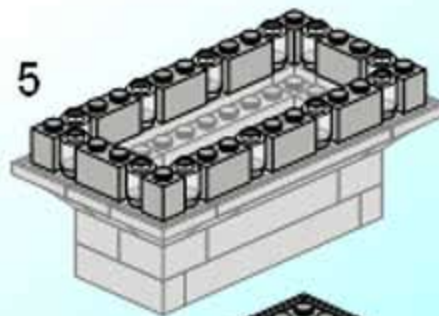
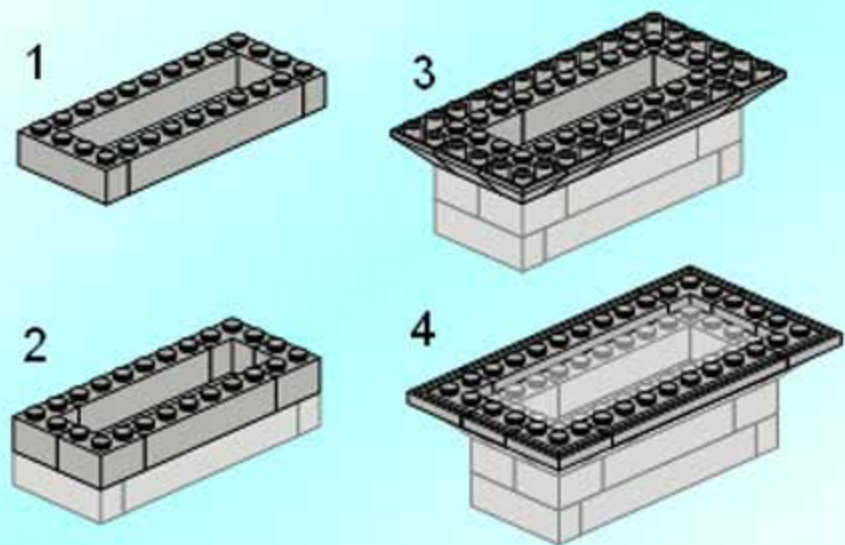
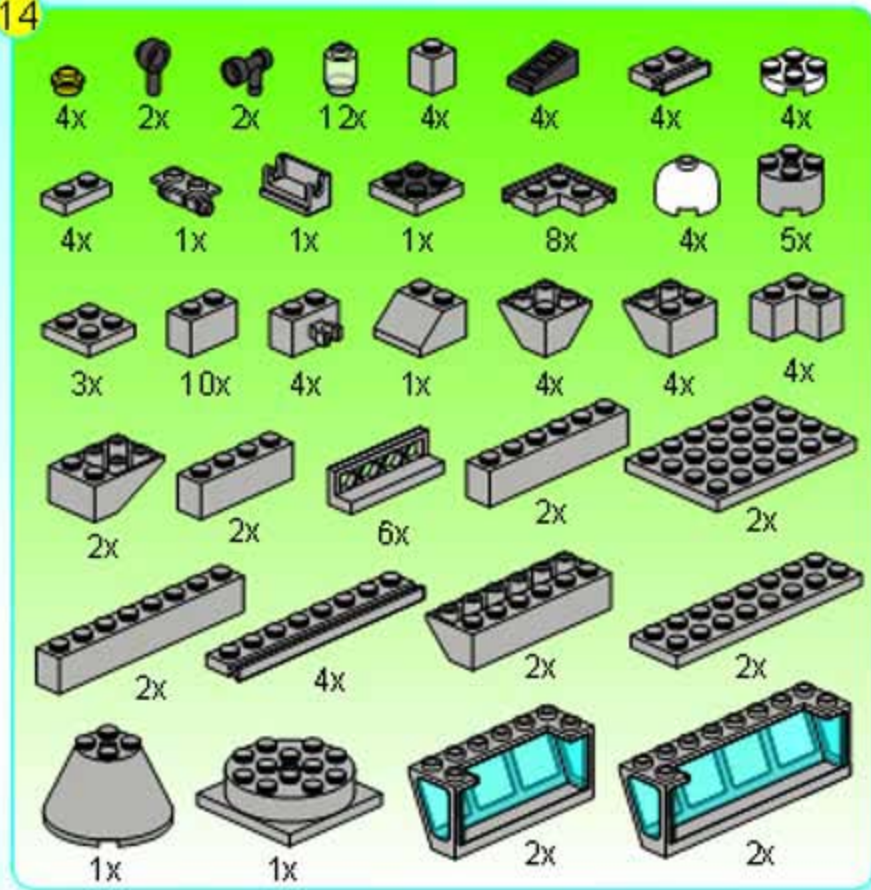



15

- 1x
- 5x
- 6x
- 6x
- 4x
- 6x
- 3x
- 3x
- 1x
- 2x
- 2x

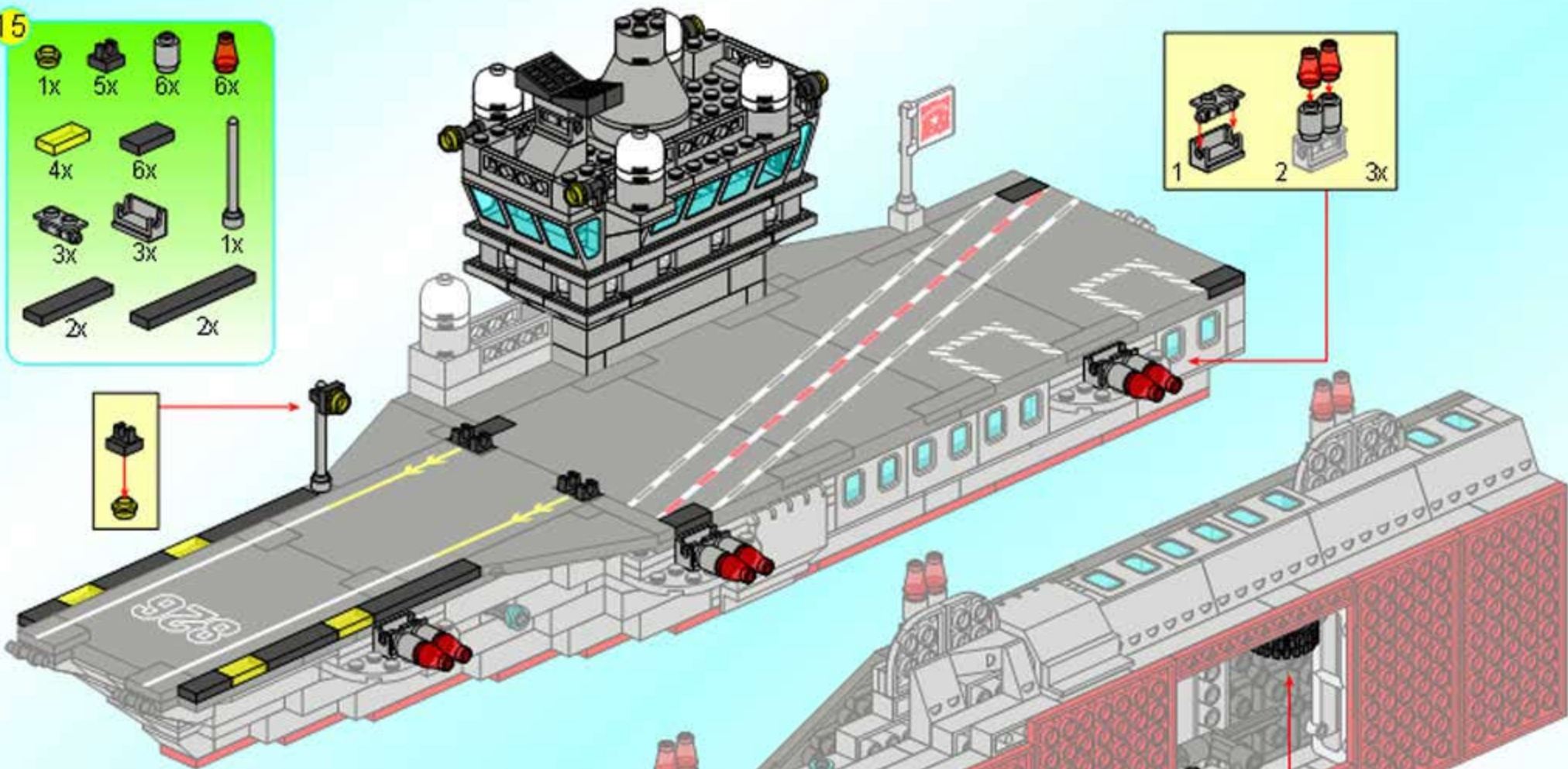
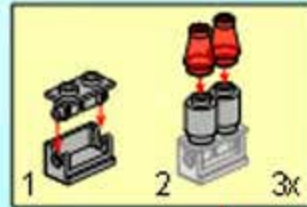

16

- 1x
- 1x
- 1x
- 1x
- 3x
- 3x
- 1x
- 1x

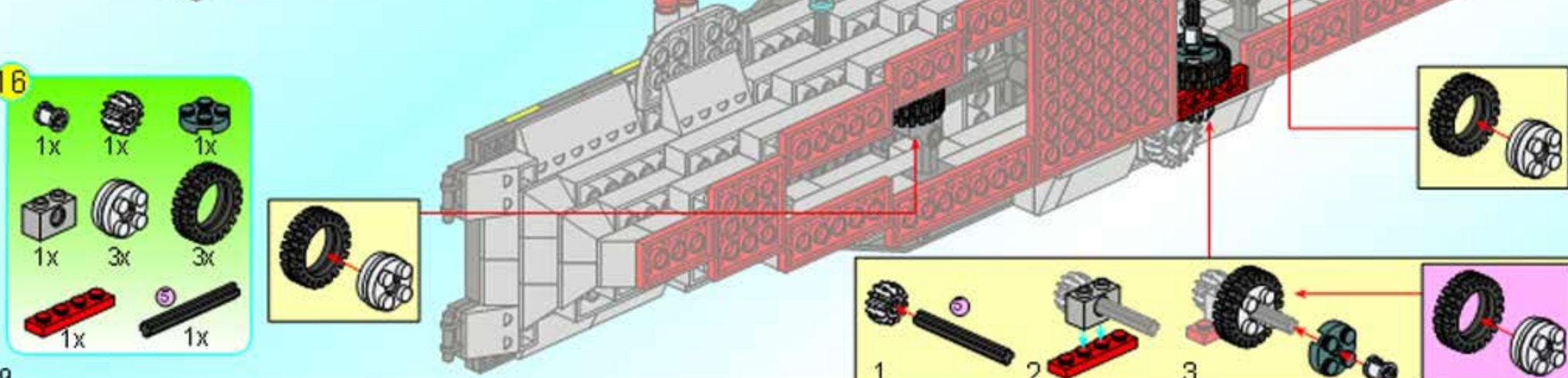
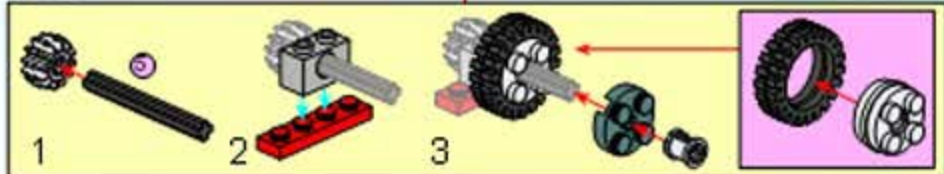



- 10x 1x 1x 4x 2x 1x 1x 6x 2x
- 2x 4x 1x 1x 6x
- 2x 2x 2x 2x 2x 4x
- 1x 1x 2x 2x
- 1x 2x 2x
- 1x 1x

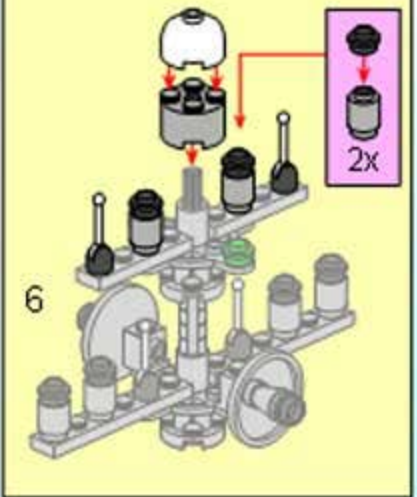
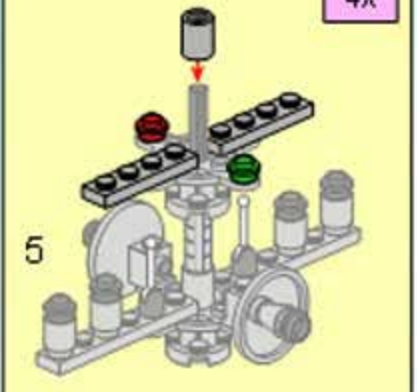
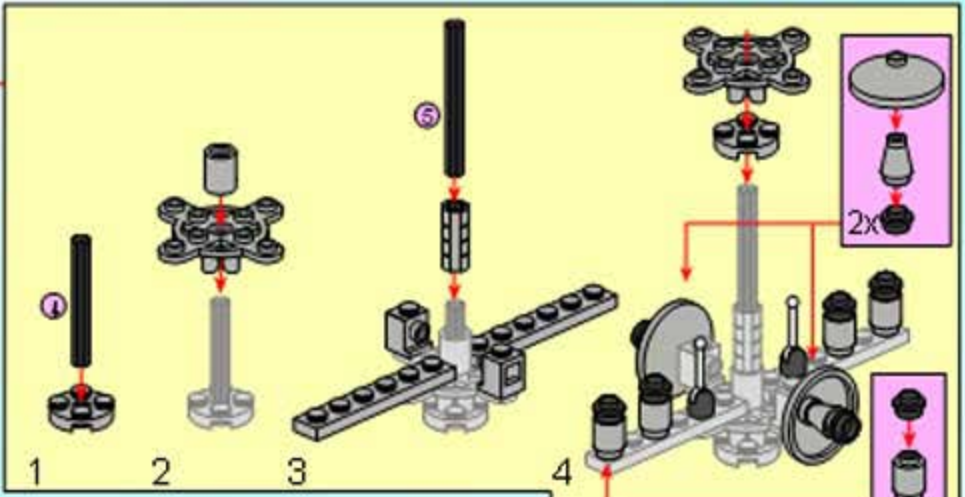
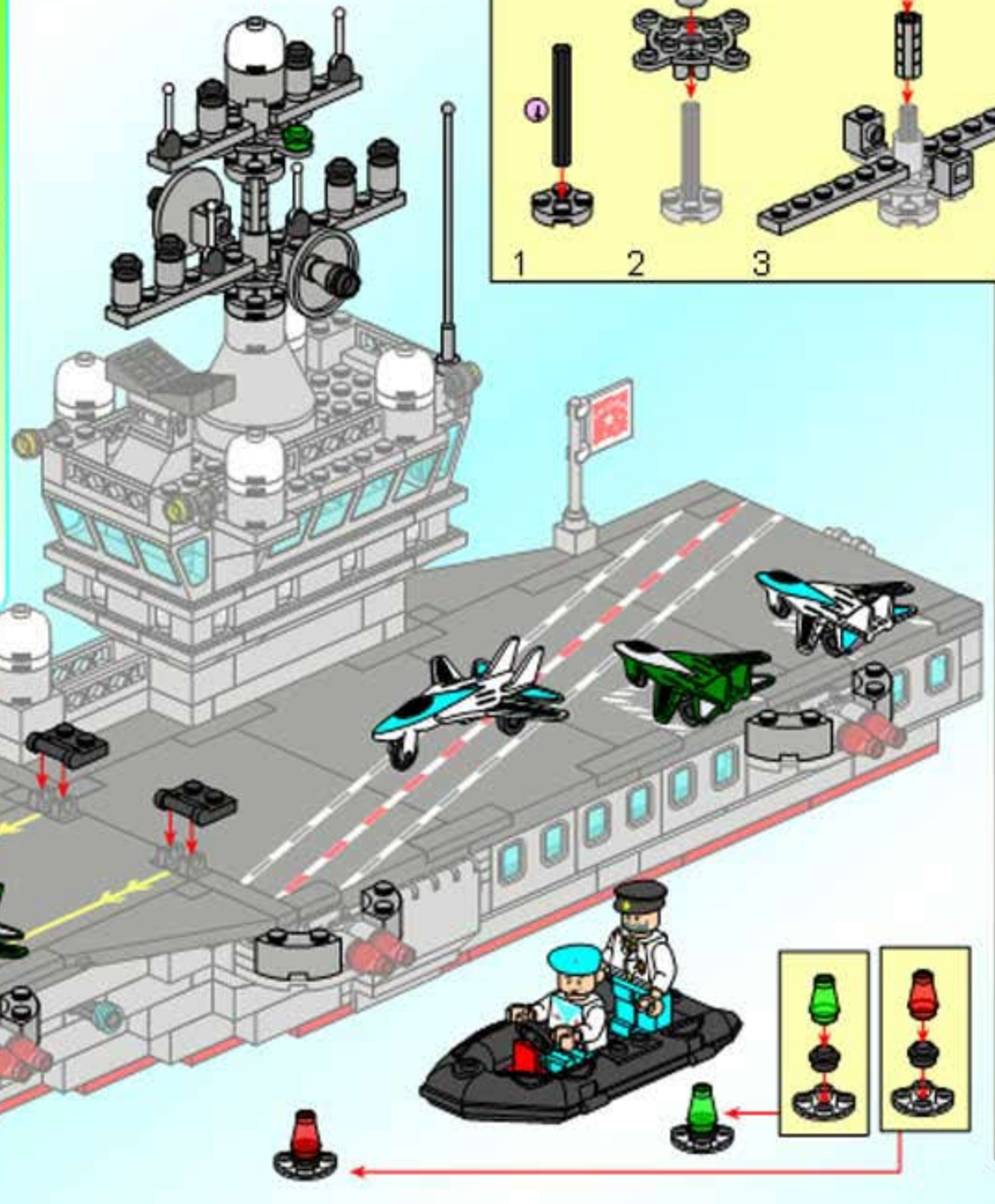
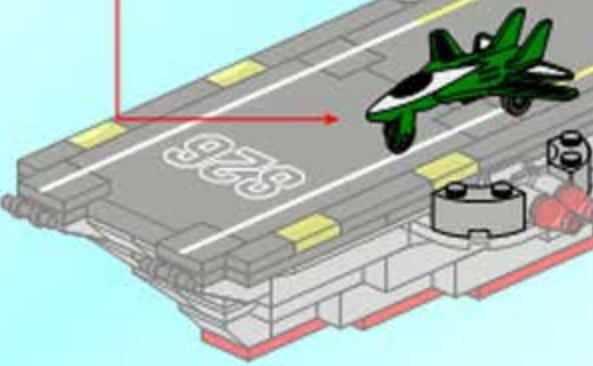





**Combat Zones**  
SERIES

